

# Zentral *CENTRAL SERVICE* STERILISATION



**Guideline for the validation of packaging processes according to ISO 11607-2**

**DGSV**  
Deutsche Gesellschaft für Sterilgutversorgung e.V.

Official publication of the German Society for Sterile Supply (DGSV e.V.)

**mhp**  
Verlag GmbH

# HAWO. PERFECTLY VALIDATED SEALING PROCESSES

Being a part of the sterile goods packaging process, the sealing process also has to be validated in accordance with ISO 11607-2 – the new packaging guideline sets out what has to be done. hawo offers compatible heat sealers and testing systems.



## HEAT SEALERS FOR HOSPITALS AND INDUSTRY

Rotary sealers are used to package instruments in hospitals and medical devices in the industrial sector. From the extremely compact and award-winning hd 680/hm 780 series to the particularly powerful pro-class hm 850/880 DC-V (see illustration) and hm 3010/20 DC-V models, virtually all hawo devices in this class feature intelligent monitoring, documentation technologies and intuitive device operation (IntelligentScan). All of the sealing devices marked with "V" (e.g. hm 850 DC-V) satisfy the requirements for process validation in accordance with ISO 11607-2 and have interfaces for connection to tracking systems.



red dot design award  
winner 2011



## HEAT SEALERS FOR DOCTOR'S SURGERIES

For the secure sterile packaging of instruments in doctors' and dentists' practices, hawo offers the particular compact bar and rotary sealers. The top-of-the-range "ValiPak" hd 380 WSI-V model (see illustration) sets the standard in the clinical practice sector with a fully ISO 11607-2-validatable process and interface for connection to practice software.

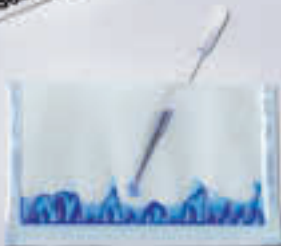

## TESTING SYSTEMS

hawo offers two testing systems for the routine monitoring of sealing seams.

- > *Seal Check: The Seal Check med indicator strips for film pouches and reels made from paper / film and Seal Check HDPE (Tyvek® / film) make faulty areas visible.*
- > *hawo InkTest: The new dye penetration test for testing the seal integrity in accordance with ISO 11607-1 is distinguished by its simple handling and delivers objective results.*



Scan the QR code and  
download the guideline  
free of charge.



## Foreword

The main purpose of any packaging system used for terminally sterilized medical devices is to preserve sterility until use as well as to allow aseptic presentation at the point of use on the patient. Validation of packaging processes is crucial to guarantee that the integrity of the packaging system is always assured and maintained during transport and storage until the time of use.

The international packaging standard ISO 11607-2 calls for suitable validated packaging processes for medical devices. This standard is applicable to the medical industry, to health care facilities (hospitals, doctors and dentists), and wherever medical devices are packaged and sterilized. The packaging process is one of the links in the process chain of medical device reprocessing and, as such, must be validated.

The establishment of a quality management system is an indispensable prerequisite for validation and for assuring reproducibility and ongoing effectiveness of medical device reprocessing. Without a quality management system validation is not possible since all steps must be defined and documented. All products and materials used must in principle meet the normative requirements. The quality management system must specify how bought-in products and services are audited and evaluated. However, the focus of this Guideline is not on audit and evaluation. The international standard ISO 11607-1 describes essential requirements for sterile barrier systems, while the ISO 11607-2 standard describes validation of packaging processes. Detailed quality requirements for sterile barrier systems are outlined in the European CEN standards EN 868-2 to 10. They serve as a basis for this Guideline and as an orientation guide for conducting validation in practice.

Experiences gained from the implementation of the requirements for validation of cleaning, disinfection and sterilization processes have highlighted the need for a practice-oriented and feasible guide for the implementation of the normative requirements so that, as far as possible, they will be similarly interpreted by operators and validators. The focus on uniform and proper conduct of validation of packaging processes is of paramount importance for everyone involved in this process as well as for the supervisory authorities and certification bodies, not least to avoid «confusion».

The authors point out that this Guideline is meant as a practical orientation guide. No guarantee of completeness is given.

### **Authors of the Guideline:**

*German Society of Sterile Supply (Deutsche Gesellschaft für Sterilgutversorgung, DGSV e. V.):*

M. Peißker, A. Schlepp, M. Lüttenberg, A. Carter, A. Jones<sup>1</sup>, B. Amann, K. Wiese

1 Section «pouch, bag or reel sealing».

# TABLE OF CONTENTS

## Guideline for Validation of Packaging Processes as per ISO 11607-2

1	Foreword
5	1 Scope
5	2 Normative bases
5	3 Prerequisites
5	4 Validation of packaging processes
5	4.1 Drafting of a validation plan
6	4.2 Conduct of validation
6	4.2.1 <i>Installation Qualification (IQ)</i>
6	4.2.2 <i>Operational Qualification (OQ)</i>
6	4.2.3 <i>Performance Qualification (PQ)</i>
8	4.3 Drafting of a validation report
8	4.4 Formal approval of the validation process
8	4.5 Process control and monitoring
8	4.6 Process changes and revalidation

## Annex A

11	Annex A.1: Validation plan checklist «pouch, reel or bag sealing»
14	Annex A.2: Installation qualification (IQ) checklist «pouch, reel or bag sealing»
18	Annex A.3: Operational qualification (OQ) checklist «pouch, reel or bag sealing»
19	Annex A.4: Performance qualification (PQ) checklist «pouch, reel or bag sealing»
20	Annex A.5: Example for determining the scope of process validation per heat sealer
21	Annex A.6: Sample standard operating procedure «pouch, reel or bag sealing»
23	Annex A.7: Sample standard operating procedure for verification of seal seams

## Annex B

- 25 Annex B.1: Validation plan checklist «sterilization sheets' folding and wrapping»
- 30 Annex B.2: Installation qualification (IQ) checklist «sterilization sheets' folding and wrapping»
- 31 Annex B.3: Operational qualification (OQ) checklist «sterilization sheets' folding and wrapping»
- 32 Annex B.4: Performance qualification (PQ) checklist «sterilization sheets' folding and wrapping»
- 34 Annex B.5: Example for determining the scope of process validation per packaging material in combination with the sterilization processes
- 35 Annex B.6: Sample standard operating procedures «sterilization sheets' folding and wrapping»
- 39 Annex B.7 : Sample specification and sample data sheet, e. g. for «sterilization sheets»

## Annex C

- 42 Annex C.1: Validation plan checklist for «filling and closing of reusable sterilization containers»
- 48 Annex C.2: Installation qualification (IQ) checklist (IQ) «filling and closing of reusable sterilization containers»
- 50 Annex C.3: Operational qualification (IQ) checklist (OQ) «filling and closing of reusable sterilization containers»
- 51 Annex C.4: Performance qualification (PQ) checklist (PQ) «filling and closing of reusable sterilization containers»
- 53 Annex C.5: Example for determining the scope of process validation per sterilization container in combination with the sterilization processes
- 54 Annex C.6: Sample standard operating procedure: «reusable sterilization containers»

## Annex D

- 55 Annex D: Sample data sheet «sterilization markers»

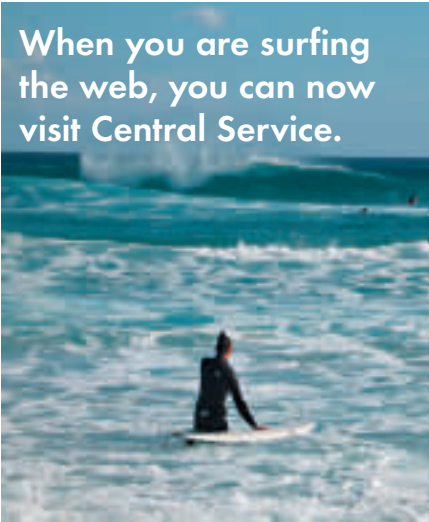

When you are surfing  
the web, you can now  
visit Central Service.

CENTRAL SERVICE  
is now accessible **online as E-Paper**,  
featuring the most convenient  
online platform currently available  
on the market.

Order your access code now  
via E-mail from  
[vertrieb@mhp-verlag.de](mailto:vertrieb@mhp-verlag.de).

**mhp**  
Verlag GmbH  
[www.mhp-verlag.de](http://www.mhp-verlag.de)



Jan Huis  
HEART Consultancy

# STERILIZATION of Medical Supplies by Steam

Volume I - General theory  
Third Revised Edition

**mhp**

mhp Verlag GmbH Westfalen

**mhp**  
Verlag GmbH  
[www.mhp-verlag.de](http://www.mhp-verlag.de)



# Guideline for Validation of Packaging Processes according to ISO 11607-2

## 1 Scope

The standard series ISO 11607 stipulates validation of the packaging processes used for industry, health care facilities and wherever medical devices are packaged and sterilized (examples of health care facilities include hospitals, doctors' and dentists' surgeries).

The ISO 11607, Part 2 standard (Article 5.1.1) explicitly calls for validation of all packaging processes. The present Guideline deals with the following packaging processes:

- pouch, reel or bag sealing<sup>2</sup>
- sterilization sheets folding and wrapping
- filling and closing of reusable sterilization containers

Likewise, packaging processes not dealt with here must also be validated as per ISO 11607-2. Non-validable packaging processes are not acceptable in practice anymore (Self Seal pouches or taped paper bags).

## 2 Normative bases

The bases for drafting this Guideline include, inter alia, the following standards<sup>3</sup>:

2 If the sealing processes were already validated in accordance with the «Guideline for validation of the sealing process as per ISO 11607-2 (Revision 1, status: July 2008)», there is no need to repeat initial validation.

3 The publication years of the pertinent standards are only given here.

4 EN 868, Part 1 has been replaced by the ISO 11607-1 standard.

5 German Standard DIN 58953, Parts 2–5 have been replaced by EN 868, Parts 2–5.

- ISO 11607-1:2009
- ISO 11607-2:2006
- EN 868:2009, Part 2-10<sup>4</sup>
- ISO 11140-1:2009
- ISO 9001:2008
- ISO 13485:2010
- DIN 58953:2010, Part 1, 6, 7, 8, 9<sup>5</sup> (German Standard)

The standards stated in table 1 are of relevance for validation and should be made accessible to the user.

## 3 Prerequisites

The packaging materials used must be suited to and defined for the intended packaging and sterilization processes. Suitability shall be determined on the basis of the information provided by the manufacturer. This includes confirmation of conformity with the ISO 11607-1 standard and pertinent sections of the EN 868, Parts 2–10 standard series, in respect of:

- microbial impermeability
- compatibility with the sterilization process.

The number of process validations to be conducted can be elucidated and defined on the basis of Table 2 (see example Annex A.5, B.5 and C.5).

The number of combinations outlined in the table can be reduced by taking account of only the maximum material stress

(worst-case scenario, while providing documentary proof to justify this).

Worst-case examples:

- Gusseted pouches and reels are more critical than flat pouches and reels.
- Steam sterilization at 134 °C/18 min is more critical than at 134 °C/5 min and 121 °C/20 min.

A further reduction can be achieved by a deliberate choice of packaging materials (e. g. see through pouch instead of paper bag).

Annex A.5, B.5 and C.5 show practical examples.

## 4 Validation of packaging processes

In principle, a documented process must be available for validation. This process comprises:

- 4.1 Drafting of a validation plan
- 4.2 Validation of packaging processes
  - 4.2.1 Installation qualification (IQ)
  - 4.2.2 Operational qualification (OQ)
  - 4.2.3 Performance qualification (PQ)
- 4.3 Drafting of a validation report
- 4.4 Formal approval of validation
- 4.5 Process control and monitoring
- 4.6 Process changes and revalidation

### 4.1 Drafting of a validation plan

The validation plan should contain, at least, the following details:

**Table 1: Standards of relevance for the validation**

ISO 11607-1	Requirements for materials, sterile barrier systems and packaging systems
ISO 11607-2	Validation requirements

**Table 2: Number of process validations to be conducted***The terms used for sterilization processes are based on the standard ISO 11140-1.*

Sterile barrier system (SBS)	STEAM			FORM (Formaldehyde)	EO (Ethylene oxide)	VH2O2 (vaporized hydrogen-peroxyde; «Plasma»)
	134 °C/ 5 min	134 °C/ 18 min	121 °C/ 20 min			
Material A						
Material B						
Material C						
Material D						

- Competences
- Description of the packaging process
- Description of the materials/equipment
- Description of the sterilization processes
- Qualification steps (IQ, OQ and PQ)

The «Validation plan» checklists in Annex A.1, B.1 and C.1 can be used.

#### 4.2 Conduct of validation

##### 4.2.1 Installation qualification (IQ)

*Definition: «Process of obtaining and documenting evidence that equipment has been provided and installed in accordance with the specification.»*

That means that technical equipment (e. g. heat sealers) must have been properly installed and users trained.

In general, the packing processes involving sterilization sheets as well as reusable sterilization containers are purely manual processes, which is why proof of IQ is based on documentation of training of staff.

It is recommended that the corresponding checklists be used to conduct installation qualification (IQ). The «Installation qualification (IQ)» checklists in Annex A.2, B.2 and C.2 can be used for documentary purposes.

##### 4.2.2 Operational qualification (OQ)

*Definition: «Process of obtaining and documenting evidence that installed equipment operates within predetermined limits when used in accordance with its operational procedures.»*

The «Operational qualification (OQ)» checklists in Annex A.3, B.3 and C.3 can be used for documentary purposes.

In principle, a distinction must be made here between automated and manual processes.

##### Automated processes

Here: pouch, reel or bag sealing.

The heat sealing process is defined on the basis of the following parameters:

- Sealing temperature,
- Contact pressure and
- Sealing time/speed (dwell).

The contact pressure and sealing speed or time (dwell) are generally set by the manufacturer of the heat sealer.

The optimum sealing temperature for the respective packaging material must be determined by the user. To that effect, the technical data sheet supplied by the manufacturer of the packaging material is needed. This must specify the sealing temperature (e. g. 170 – 200 °C).

Sealing samples must be produced for the respective lower and upper limits.

The quality properties listed in ISO 11607-2, § 5.3.2 b must be assured:

- intact seal for a specified seal width
- no channels or open seals
- no punctures or tears
- no material delamination or separation

These quality properties must be verified and documented by means of suitable processes. The test methods in Table 3, for example, can be used as a guide.

Then the sealing temperature must be specified for routine operations. In general this is calculated from the mean value of the limit values (e. g. mean value from 170 °C and 200 °C is 185 °C).

##### Manual processes

Here: sterilization sheets' folding and wrapping; filling and closing of reusable sterilization containers<sup>9</sup>.

First, the most critical packaging configuration must be determined (worst case).

Examples include:

- the heaviest and largest tray (container)
- large, unwieldy single instruments

Then these configurations must be packed according to the standard operating procedures.

When checking the sterile barrier systems produced all defined quality properties as well as the correct packing method set out in the standard operating procedure (see Annex B.6 and C.6) must be assured.

Pursuant to the ISO 11607-2, § 5.3.2 c standard the quality properties required for sterilization sheets and reusable sterilization containers are as follows:

- continuous closeness/integrity
- no punctures or tears (not applicable to reusable sterilization containers)
- no other visible damage or material irregularities<sup>10</sup>.

The quality properties must be verified and documented by means of suitable processes or tests. For the combinations specified in the validation plan, 10 sterile barrier systems of the same material must be packed and their quality properties checked. To document the quality properties it is recommended that at least one photo is taken of each sample.

##### 4.2.3 Performance qualification (PQ)

*Definition: «Process of obtaining and documenting evidence that the equipment, as installed and operated in accordance with operational procedures, consistently performs in accordance with predetermined criteria and thereby yields product meeting its specification.»*

During performance qualification proof must be provided after sterilization that the process is under control and produces optimally sealed or closed sterile barrier systems.



**Table 3: Test methods for verification of quality properties**

Test method	Suitable for verification of the following quality properties
Seal integrity test (e. g. «dye penetration test/InkTest» according to ISO 11607-1, Annex B <sup>6</sup> )	<ul style="list-style-type: none"> <li>– channels or open seals</li> <li>– punctures or tears</li> </ul>
Seal integrity indicator <sup>7</sup> (e. g. Seal Check)	<ul style="list-style-type: none"> <li>– intact seal for a specified seal width</li> <li>– channels or open seals</li> <li>– punctures or tears</li> </ul>
Peel test according to EN 868, Annex E	<ul style="list-style-type: none"> <li>– material delamination or separation</li> </ul>
Visual inspection <sup>8</sup>	<ul style="list-style-type: none"> <li>– intact seal for a specified seal width</li> <li>– punctures or tears</li> </ul>

The «Performance qualification (PQ)» checklists in Annex A.4, B.4 and C.4 can be used for documentation purposes.

Here, too, a distinction must be made between automated and manual processes.

#### **Automated processes**

Verification is done by means of the seal strength test as per EN 868-5, Annex D<sup>11</sup>. The packaging must be sterilized before verification. The protocols/logs (batch documentation) related to the sterilization processes are part of validation.

For the defined combinations (see also Annex A.5) three empty pouches or reels of the same material must be sealed, clearly labelled (sealing device, serial number, sealing parameters) and then sterilized with the specified sterilization program (reels must be sealed at both ends). Each pouch must be added to a different sterilization load to take account of all the factors exerting an influence on the sterilization loads.

The test (as per EN 868-5, Annex D) is carried out as follows:

- Cuts measuring 15 mm in width are taken of the dried samples and at an angle of 90 ° to the seal seam. At least one sample of a produced seal seam must be taken from each packaging<sup>12</sup>. If only one sample of a seal seam is taken, the sample must be taken from around the centre.
- Simulation of the peeling process at a speed of 200 mm/min

- Recording of the seal seam strength<sup>13</sup>
- Evaluation and documentation of the results

The results of the seal strength test are confirmed in a report, containing at least the following information:

- Manufacturer and type of heat sealer
- Serial number of heat sealer
- Specification of the sealing parameters
- Identification of the verified product
- Maximum strength of seal of each sample measured in N/15 mm width
- Whether verification was done with the free end supported or not
- The frequency used (data per second of measurement)
- Test device (manufacturer, designation)/last calibration
- Graphic display of resistance
- Date of test

Testing of the sealed and sterilized pouches can, for example, be carried out by an accredited test laboratory or by the device/material manufacturer.

The maximum strength must be entered into the table in Annex A.4. The maximum strength is the relevant value for assessment and, as per EN 868-5, must be greater than or equal to 1.5 N/15 mm width<sup>14</sup>. If the maximum tensile strength of one of the three tests is less than 1.5 N/15 mm width, PQ is deemed to have failed.

In addition the quality properties listed in ISO 11607-2, § 5.3.2 b must be assured:

- intact seal for a specified seal width

- no channels or open seals
- no punctures or tears
- no material delamination or separation

These quality properties must be verified and documented by means of suitable processes. The test methods in Table 3, for example, can be used as a guide.

#### **Manual processes**

For the test, sterilized packaging systems must be taken from the running processes. From three different cycles (batches) one sample must be taken in each case. The batch documentation (protocols) of the respective sterilization processes is part of validation.

6 The basis for this test method is ASTM F1929 2 «Standard test method for detecting seal leaks in porous medical packaging by dye penetration»

7 The seal integrity indicator must not under any circumstances be cut since it must always be guaranteed that the entire pinch roller of the sealing device is printed off. Furthermore, the seal indicator shall always be made of the same type of material as the porous part of the packaging (medical grade paper as per EN 868-3 or HDPE as per EN 868-9/10)

8 For visual inspection standardized test methods can be used (e. g. ISO 11607-1, Annex B [ASTM F1886])

9 The partial step «Filling of pouches and reels» is also a manual process and must be set out in a standard operating procedure. The heat sealing process itself is normally fully automated.

10 The ISO 11607-2 standard uses «No material delamination or separation» here.

11 Alternatively, the test method as per ASTM F88 can be used (validated and round robin approved test method).

12 EN 868-5:1999 specified five samples per seal seam. EN 868-5:2009 stipulates only one sample per seal seam. Additional samples may be needed if the length of a seal is more than 500 mm.

13 For further evaluation and documentation it is advisable to specify as a value the maximum (required as per EN 868-5 Annex D.3) and additionally the average tensile strength.

14 EN 868-5, § 4.5.1 «The minimum seal strength value for steam sterilization processes must be 1.5 N per 15 mm in health care facilities and 1.2 N per 15 mm in other sterilization processes in health care facilities». However, stipulation of a minimum value of 1.5 N/15 mm is recommended for all sterilization processes.

Assurance of the quality properties must be verified for each packaging system (sample).

Pursuant to standard ISO 11607-2, § 5.3.2 c the quality properties for sterilization sheets and reusable sterilization containers are as follows:

- continuous closeness/integrity
- no punctures or tears (not applicable to reusable sterilization containers)
- no other visible damage or material irregularities<sup>15</sup>.

These quality properties must be verified and documented by means of suitable processes or tests. The sterile barrier systems or packaging systems are opened one step after the other, verified and documented (for photographic documentation see Annex B.8/C.7).

#### 4.3 Drafting of a validation report

The validation procedures and results must be documented in a summary report. The checklists, protocols and any photographic documentation used serve as evidence and must be enclosed in an annex to the report.

The report must contain, at least, the following information:

Validation plan

- Evidence of implementation of the validation plan (IQ, OQ and PQ checklists completed as per Annex)
- Evaluation of the results
- Photographic documentation for manual packing processes
- Details and explanation of any deviations from validation plan
- Formal approval of validation
- Process control and monitoring
- Process changes and revalidation

#### 4.4 Formal approval of validation

Validation, as documented and evaluated in the report, must be formally approved, and duly documented, by the competent person appointed by the operator. This can be recorded, for example, in a field provided to that effect in the validation plan. If all validation results are not accepted, this must be clearly documented, including assessment of any remaining risks.

#### 4.5 Process control and monitoring

The routine tests that are established during the validation as being necessary must be documented (e. g. in the standard operating procedure). This is intended as a means of ensuring that changes in the packaging process are detected on time before they compromise the sterile barrier systems and the requirements are no longer met. These include, e. g.:

- Visual inspection<sup>16</sup>
- Peelability (e. g. peel test as per EN 868-5, Annex E «Method for determination of the peel characteristics of paper/plastic laminate products»)
- Seal integrity test (e. g. dye penetration test/ink test as per ISO 11607-1, Annex B<sup>17</sup>)
- Seal integrity indicator<sup>18</sup> (e. g. Seal Check)
- Tensile strength of seal seam (e. g. determination of seal seam strength as per EN 868-5, Annex D «Method for determination of the seal seam strength of pouches and reels»)
- Stepwise opening of packaging (in the case of sterilization sheets or reusable sterilization containers).

Intervals (e. g. daily, weekly, monthly, yearly) and acceptance values must be defined for the routine tests needed, including the action to be taken if a test result is not satisfactory. The routine test results must be documented. This procedure must be set out in the quality management system.

#### 4.6 Process changes and revalidation

Processes must be revalidated:

- Unscheduled revalidation,
  - for example in the event of changes to materials, processes, including changes to equipment or occurring during sterilization (revalidation)
- Scheduled revalidation,
  - at regular intervals, i. e. in general after one year if no changes were made to materials, sealing process or sterilization (performance requalification).
  - provides evidence that the packaging process continues to be within the limits defined at the time of ini-

tial validation (IQ, OQ and PQ). That no changes were made to materials, processes or sterilization compared to the previous validation must be confirmed in the revalidation report. If changes are made to materials, processes or sterilization how such changes will affect the packaging process results must be elucidated. The results must be documented. Based on these, an individual revalidation plan must be drafted. Accordingly, in the event of material changes, for example, operational qualification (OQ) and performance qualification (PQ) must be partially or fully repeated, and if changes are made to the packaging process or to the equipment used installation qualification (IQ) must also be repeated. For revalidation it must be ensured that the documents used meet the current requirements. The checklists must be updated if necessary. An individual validation plan is required for each revalidation or performance requalification. The «Validation plan» checklists in Annex A.1, B.1 and C.1 can be used. ■

15 The ISO 11607-2 standard uses «No material delamination or separation» here.

16 For visual inspection standardized test methods can be used (e. g. ISO 11607-1, Annex B [ASTM F1886] for seal seams or EN 868-8 for reusable sterilization containers.

17 The basis for this test method is ASTM F1929 «Standard test method for detecting seal leaks in porous medical packaging by dye penetration».

18 The seal integrity indicator must not under any circumstances be cut since it must always be guaranteed that the entire pinch roller of the sealing device is printed off. Furthermore, the seal integrity indicator shall always be made of the same type of material as the porous part of the packaging (medical grade paper as per EN 868-3 or HDPE as per EN 868-9/10)

The Trade Association for producers of Sterile Barrier Systems

# SBA

Sterile Barrier Association



SBA members are multinational producers of Sterile Barrier Systems with extensive product ranges



Expert advice on the design of Sterile Barrier Systems, compatible sterilisation methods, opening, safe presentation and disposal



Let us partner you to meet the requirements of global standards and regulations

*Protecting the Patient*



## Responsibility is our commitment

Medical packaging made in Germany. Stericlin<sup>®</sup> quality manufacturing, setting and upholding standards for more than 40 years worldwide.

- Laminates paper/film
- Laminates Tyvek<sup>®</sup>/film
- Laminates non woven /film
- Non woven wrapping
- SMS wrapping materials
- Crepe paper wrapping
- Bowie&Dick test
- Indicators
- Batch Monitoring Systems
- Labels
- Packaging materials for medical device manufacturers

Our quality assures customers around the world that stericlin<sup>®</sup> is a superior choice. It is our daily mission to manufacture the highest quality product in the world market.

Tyvek<sup>®</sup> is a registered trademark of DuPont

## Annex A.1: Validation plan checklist «pouch, reel or bag sealing»<sup>19</sup>

- Initial validation
- Revalidation (at regular intervals, only performance requalification)
- Revalidation for special reasons (e. g. new materials)

### a) Competences

Name of institution (operator)	
Location	
Validator (Name of persons, or companies, conducting validation)	
Responsible for overall validation	

### b) Description of sealing device

Manufacturer of sealing device	
Type of sealer (e. g. rotary sealer)	
Serial number	
Supplier	
Last calibration	
Contact person	

### c) Description of material

Manufacturer			
Type of material			
Manufacturer's QM certificate available?*	<input type="checkbox"/> Yes	<input type="checkbox"/> No	<input type="checkbox"/> Evidence
Supplier			
Contact person			
CE conformity?*	<input type="checkbox"/> Yes	<input type="checkbox"/> No	<input type="checkbox"/> Evidence
Specification of material to be sealed **	<input type="checkbox"/> Paper/foil <input type="checkbox"/> Tyvek® <sup>20</sup> /foil <input type="checkbox"/> Nonwovens/foil	<input type="checkbox"/> Paper/paper <input type="checkbox"/> Nonwovens/nonwovens Other: _____	
ISO 11607 Part 1 conformity? * <sup>21</sup>	<input type="checkbox"/> Yes	<input type="checkbox"/> No	<input type="checkbox"/> Evidence
Sealing temperature range (in °C)*	from _____ to _____ Specification of: _____ <input type="checkbox"/> Evidence available		
Compatible with sterilization process*	<input type="checkbox"/> Yes	<input type="checkbox"/> No	<input type="checkbox"/> Evidence

\* Information featuring an \* must, in accordance with EN 868-5 and ISO 11607-1, be made available by the manufacturer of the packaging material.

\*\* For each material combination or each category of heat sealable sterile barrier systems a complete checklist must be filled out and the validation process conducted.

<sup>19</sup> If other sealing methods are used, a customized checklist must be compiled if necessary.

<sup>20</sup> Tyvek® is a registered trademark of E.I. du Pont de Nemours.

<sup>21</sup> Conformity with ISO 11607-1 is an absolute prerequisite and in general includes conformity with EN 868-5. Often, CE conformity and conformity with ISO 11607 Part 1 are declared jointly in one document.



**d) Description of sterilization process**

Sterilization process	<input type="checkbox"/> STEAM		
Sterilization process validated?	<input type="checkbox"/> Yes	<input type="checkbox"/> No	
Validated by:			
Last validation:			
Validation report number(s): (if there is more than one sterilizer)			
Next validation:			

Sterilization process	<input type="checkbox"/> EO (ethylene oxide)		
Sterilization process validated?	<input type="checkbox"/> Yes	<input type="checkbox"/> No	
Validated by:			
Last validation:			
Validation report number(s): (if there is more than one sterilizer)			
Next validation:			

Sterilization process	<input type="checkbox"/> VH2O2 (plasma)		
Sterilization process validated?	<input type="checkbox"/> Yes	<input type="checkbox"/> No	
Validated by:			
Last validation:			
Validation report number(s): (if there is more than one sterilizer)			
Next validation:			

Sterilization process	<input type="checkbox"/> FORM (formaldehyde)		
Sterilization process validated?	<input type="checkbox"/> Yes	<input type="checkbox"/> No	
Validated by:			
Last validation:			
Validation report number(s): (if there is more than one sterilizer)			
Next validation:			

Sterilization process	<input type="checkbox"/> Other : _____		
Sterilization process validated?	<input type="checkbox"/> Yes	<input type="checkbox"/> No	
Validated by:			
Last validation:			
Validation report number(s): (if there is more than one sterilizer)			
Next validation:			

**I e) Qualification steps**

If this is an initial validation, all three qualification steps (IQ, OQ and PQ) must be carried out as per the checklists in Annex A.2, A.3 and A.4. For revalidation/performance requalification it may be possible to omit some steps.

<b>Installation qualification (IQ)</b>	<input type="checkbox"/> executed		
	<input type="checkbox"/> already executed during validation on: _____		
	<input type="checkbox"/> passed	<input type="checkbox"/> failed	
	Date/signature : _____		
<b>Operational qualification (OQ)</b>	<input type="checkbox"/> executed		
	<input type="checkbox"/> already executed during validation on: _____		
	<input type="checkbox"/> passed	<input type="checkbox"/> failed	
	Date/signature : _____		
<b>Performance qualification (PQ)</b>	<input type="checkbox"/> executed		
	<input type="checkbox"/> passed	<input type="checkbox"/> failed	
	Date/signature : _____		

**I f) Formal approval of validation/revalidation by the operator**

- All parts of validation/revalidation passed
- Parts of validation/revalidation failed
- Measures have been defined and documented

*Place, date* \_\_\_\_\_

*Name* \_\_\_\_\_

*Signature* \_\_\_\_\_

## Annex A.2: Installation qualification (IQ) checklist «pouch, reel or bag sealing»<sup>22</sup>

Are standard operating procedures (SOPs) available? (example, see Annex A.6)	<input type="checkbox"/> Yes	<input type="checkbox"/> No	<input type="checkbox"/> Where? _____
---	------------------------------	-----------------------------	---------------------------------------

### I a) General data

Device (designation/number)			
Manufacturer			
Manufacturer's address			
Quality management system	<input type="checkbox"/> Evidence available (certificate):		
Type of sealer (e. g. rotary sealer)			
Serial number			
Year of manufacture			
Location			
Responsible for validation			
Other IQ inspectors			
Date of test			
Type of device	<input type="checkbox"/> Bar sealer		<input type="checkbox"/> Serial device
	<input type="checkbox"/> Rotary sealer		<input type="checkbox"/> Special device from manufacturer
	<input type="checkbox"/> Modified device modified by:		
CE conformity? <sup>23</sup>	<input type="checkbox"/> Yes	<input type="checkbox"/> No	<input type="checkbox"/> Evidence
ISO 11607-2 conformity? <sup>24</sup>	<input type="checkbox"/> Yes	<input type="checkbox"/> No	<input type="checkbox"/> Evidence
Service team			
Address			
Telephone number			
Contact person			
Authorized by the manufacturer	<input type="checkbox"/> Yes, evidence <sup>25</sup> : _____		<input type="checkbox"/> No

<sup>22</sup> If other sealing methods are used, a customized checklist must be compiled if necessary.

<sup>23</sup> A heat sealer is neither a medical device nor an accessory to a medical device according to the European Medical Device Directive.

<sup>24</sup> Conformity with ISO 11607-2 is an absolute prerequisite.

<sup>25</sup> Authorization by the manufacturer must be available in the written form.

**b) Installation conditions**

Parameters	Required	Available (measured)
Tension in volts	220 – 240 Volt	<input type="checkbox"/> Yes
Frequency in Hz	50/60 Hz	<input type="checkbox"/> Yes
Fuse protection in ampere <sup>26</sup>		<input type="checkbox"/> Yes
Air flow rate (only for vacuum devices) <sup>27</sup>		<input type="checkbox"/> Yes
Compliance	<input type="checkbox"/> Yes <input type="checkbox"/> No	Date/signature : _____

**c) Documentation**

Document	Available		Where (archival site)
Operating instructions	<input type="checkbox"/> Yes	<input type="checkbox"/> No	
Spare parts/Order list	<input type="checkbox"/> Yes	<input type="checkbox"/> No	
Compliance	<input type="checkbox"/> Yes	<input type="checkbox"/> No	Date/signature : _____

**d) Safety features**

Parameters	Required	Available
Seal seam width	6 mm <sup>28</sup>	
Distance to medical device	30 mm <sup>29</sup>	
Compliance	<input type="checkbox"/> Yes <input type="checkbox"/> No	Date/signature : _____

In general, the operating instructions suffice as evidence of these aspects. In addition, the following aspects must be verified by an authorized person:

Description	Compliance		Remarks
Has the sealing device been properly connected?	<input type="checkbox"/> Yes	<input type="checkbox"/> No	
Is the sealing device free of visual safety defects (defective casing, power cables, connector, etc.)?	<input type="checkbox"/> Yes	<input type="checkbox"/> No	
Is the sealing device free of functional defects (unknown running noise, clattering, grating, etc.)?	<input type="checkbox"/> Yes	<input type="checkbox"/> No	
Compliance	<input type="checkbox"/> Yes	<input type="checkbox"/> No	Date/signature : _____

<sup>26</sup> Please consult the manufacturer's instructions for the fuse protection required.

<sup>27</sup> Please consult the manufacturer's instructions for the air flow rate required.

<sup>28</sup> EN 868-5 § 4.3.2 «The overall width of the seal(s) shall be not less than 6 mm. For ribbed seals, the sum of the widths of the ribs shall be not less than 6 mm».

<sup>29</sup> German standard DIN 58953-7 § 6.3.1 «Beneath the seal seam at least 30 mm must be left between the sterile item and the seal seam».

### I e) Critical parameters

The following other aspects must be defined or verified by the user (evidence required in some cases):

Which parameters have been defined as critical during process development? <sup>30</sup>	<input checked="" type="checkbox"/> Sealing temperature		<input checked="" type="checkbox"/> Contact pressure
	<input type="checkbox"/> Sealing time		<input type="checkbox"/> Sealing speed
Issues to be clarified	Compliance		Evidence based on
Are the critical parameters monitored?	<input type="checkbox"/> Yes	<input type="checkbox"/> No	
Are there systems available which, in the event of deviation from pre-determined limit values for critical process parameters, trigger an alarm or warning or bring the device to a standstill? <sup>31</sup>	<input type="checkbox"/> Yes	<input type="checkbox"/> No	
Are these critical process parameters routinely controlled and monitored? <sup>32</sup>	<input type="checkbox"/> Yes	<input type="checkbox"/> No	
Compliance	<input type="checkbox"/> Yes	<input type="checkbox"/> No	Date/signature : _____

The following other aspects must be confirmed by providing appropriate evidence:

Issues to be clarified	Compliance		Evidence based on
Has the sealing device been serviced and are written servicing plans available?	<input type="checkbox"/> Yes	<input type="checkbox"/> No	
Have the essential sensors (e. g. temperature sensor and DMS module) to the process been calibrated and are written calibration plans available?	<input type="checkbox"/> Yes	<input type="checkbox"/> No	
Compliance	<input type="checkbox"/> Yes	<input type="checkbox"/> No	Date/signature : _____

In addition, the following must be simulated and documented:

Are the parameter settings preserved in the event of power failure?	<input type="checkbox"/> Yes	<input type="checkbox"/> No	
Compliance	<input type="checkbox"/> Yes	<input type="checkbox"/> No	Date/signature : _____

30 ISO 11607-2 § 5.2.2 «Critical process parameters shall be defined». Note: For rotary sealers the critical parameters include at least the sealing temperature and contact pressure (monitoring of the sealing speed is recommended additionally). For bar sealers the critical parameters are sealing temperature, contact pressure and sealing time».

31 ISO 11607-2 § 5.2.4 «Alarms, warning systems or machine stops shall be challenged in the event that critical process parameters exceed predetermined limits».

32 ISO 11607-2 § 5.6.2 «The critical process parameters shall be controlled and monitored».





Annex A.3: Operational qualification (OQ) checklist «pouch, reel or bag sealing»<sup>33</sup>

Criterion	Lower limit (LL)	Upper limit (UL)
1. Target temperature (as per packaging manufacturer = M <sup>34</sup> )	LLM =	ULM =
2. Actual temperature during test (measured/read)	LL =	UL =
3. Requirement	LL ≥ LLM	UL ≤ ULM
4. Compliance with requirement from line 3	<input type="checkbox"/> Yes	<input type="checkbox"/> No
Quality properties	Compliance	Compliance
Intact seal for a specified seal width	<input type="checkbox"/> Yes	<input type="checkbox"/> No
Evidence based on		
Test method: _____*	_____ Name/signature	_____ Name/signature
No channels or open seals	<input type="checkbox"/> Yes	<input type="checkbox"/> No
Evidence based on		
Test method: _____*	_____ Name/signature	_____ Name/signature
No punctures or tears	<input type="checkbox"/> Yes	<input type="checkbox"/> No
Evidence based on		
Test method: _____*	_____ Name/signature	_____ Name/signature
No material delamination or separation	<input type="checkbox"/> Yes	<input type="checkbox"/> No
Evidence based on		
Test method: _____*	_____ Name/signature	_____ Name/signature
Temperature (T) defined for PQ (mean value from upper and lower limit values of actual temperature at the time of testing)	T = _____	

\* Test methods are given in Table 3.

<sup>33</sup> If other sealing methods are used, a customized checklist must be compiled if necessary.

<sup>34</sup> If special materials are used (e. g. HDPE), limit values must also be calculated in sample seals if necessary.

**Annex A.4: Performance qualification (PQ) checklist «pouch, reel or bag sealing»<sup>35</sup>**

Temperature defined for the sealing process in the decontamination circuit (carried forward from OQ checklist)	T = _____			
Target temperature for operational qualification (carried forward from OQ checklist)	LL = _____		UL = _____	
Switch-off tolerance in degree Celsius as per DIN 58953-7:2010 (max. $\pm 5$ °C) <sup>36</sup>	SO = _____			
Resultant upper and lower value	T - SO	=	T + SO	=
Requirements	T - SO $\geq$ LL		T + SO $\leq$ UL	
Compliance with requirements	<input type="checkbox"/> Yes	<input type="checkbox"/> No	<input type="checkbox"/> Yes	<input type="checkbox"/> No

Criteria	Sterilization cycle (batch) A		Sterilization cycle (batch) B		Sterilization cycle (batch) C	
Date/time of sterilization						
Sterilization protocol (log) available and correct process sequence confirmed	<input type="checkbox"/> Yes	<input type="checkbox"/> No	<input type="checkbox"/> Yes	<input type="checkbox"/> No	<input type="checkbox"/> Yes	<input type="checkbox"/> No
Sealing parameters:						
Sealing temperature						
Contact pressure						
Sealing speed/sealing time (dwell)						
Seal strength test						
Free end supported	<input type="checkbox"/> Yes	<input type="checkbox"/> No	<input type="checkbox"/> Yes	<input type="checkbox"/> No	<input type="checkbox"/> Yes	<input type="checkbox"/> No
Maximum strength						
Sample	A :		B :		C :	
Strength value (Smax)						
Test passed (if all values Smax $\geq$ 1.5 N)	<input type="checkbox"/> Yes	<input type="checkbox"/> No	<input type="checkbox"/> Yes	<input type="checkbox"/> No	<input type="checkbox"/> Yes	<input type="checkbox"/> No
Evidence based on (name of laboratory or company)						
Verification of quality properties:						
Sample	A :		B :		C :	
Intact seal for a specified seal width Test method: _____*	<input type="checkbox"/> Yes	<input type="checkbox"/> No	<input type="checkbox"/> Yes	<input type="checkbox"/> No	<input type="checkbox"/> Yes	<input type="checkbox"/> No
No channels or open seals Test method: _____*	<input type="checkbox"/> Yes	<input type="checkbox"/> No	<input type="checkbox"/> Yes	<input type="checkbox"/> No	<input type="checkbox"/> Yes	<input type="checkbox"/> No
No punctures or tears Test method: _____*	<input type="checkbox"/> Yes	<input type="checkbox"/> No	<input type="checkbox"/> Yes	<input type="checkbox"/> No	<input type="checkbox"/> Yes	<input type="checkbox"/> No
No material delamination or separation Test method: _____*	<input type="checkbox"/> Yes	<input type="checkbox"/> No	<input type="checkbox"/> Yes	<input type="checkbox"/> No	<input type="checkbox"/> Yes	<input type="checkbox"/> No

\* Test methods are given in Table 3.

<sup>35</sup> If other sealing methods are used, a customized checklist must be compiled if necessary.

<sup>36</sup> If special materials are used (e. g. HDPE), narrower switch-off tolerances must be defined if necessary (e. g.  $\pm 3$  °C instead of  $\pm 5$ °C).

### Annex A.5: Example for determining the scope of process validation per heat sealer

#### *Example from everyday practice*

A Central Sterile Supply Department (CSSD) has two heat sealers, three different steam sterilization programs as well as one formaldehyde sterilizer and one «plasma sterilizer», each with one program.

Materials are assigned as follows:

Sealer 1	STEAM			FORM (formaldehyde)	EO (ethylene oxide)	VH2O2 (plasma)
	134 °C 5 min	134 °C 18 min	121 °C 20 min			
Material A (see through flat pouch)	×	×	×	×		
Material B (see through gusseted pouch)	×	×*	×	×		
Material C (Tyvek®)						
Material D (paper bag)	×*					
Sealer 2	STEAM			FORM (formaldehyde)	EO (ethylene oxide)	VH2O2 (plasma)
	134 °C 5 min	134 °C 18 min	121 °C 20 min			
Material A (see through flat pouch)						
Material B (see through gusseted pouch)						
Material C (Tyvek®)						×*
Material D (paper bag)						

The ten combinations outlined in the table can be reduced by taking account of only the maximum material stress (worst-case scenario, while providing documentary proof to justify this; in this example for material A and B: 134 °C/18 min as well as see through gusseted pouch). This combination is marked with an ×\* in the table.

The seal seam is subjected to the greatest stress during steam sterilization, hence this must be viewed as a «worst case». Here in turn the program with the higher temperature must be first considered and then the longer exposure time with the same temperature.

This example shows that in total validation must be carried out three times. A further reduction can be achieved by a deliberate choice of sterile barrier system (e. g. see through flat pouch instead of paper bag). Accordingly, for this example the number of validations needed would be reduced from three to two.

Logo of Institution	Quality Management Manual	Page of page
Department	Scope	Revision

### Annex A.6: Sample standard operating procedure «heat sealing»

*Note: the German standard DIN 58953-7, § 6.3 gives a guide to packing in pouches and reels. That guide has been used as a basis for compiling this sample standard operating procedure (SOP).*

#### 1. Selecting pouches or reels

Select preformed pouches in accordance with the size of the medical device (MD).

If no preformed pouches are available in the correct size, cut reels to an appropriate size and seal at the lower edges such that the reel section can be filled like a pouch. Alternatively, a preformed pouch can also be shortened. Neither the sterile barrier system nor the protective packaging should be kinked or folded.

The MD may occupy at most 75 % of the pouch (DIN 58953-7).

The width chosen must allow for unimpeded introduction of the MD, but it is not advisable to use a bigger size.

The space between the upper end of the MD and the seal seam on the peeling side must be at least 3 cm (DIN 58953-7).

After sealing, an excess of at least 1 cm must be left above the seal seam (recommended in practice: 2–3 cm) to allow for unimpeded peeling as well as aseptic withdrawal (DIN 58953-7).

When using gusseted pouches or reels the distance to the seal seam should be markedly more than 3 cm to permit orderly sealing of original folds (the folded foil lies evenly on the paper side to prevent formation of any additional folds).

#### 2. Packing the medical device

Insert the MD into the see through pouch such that the user can hold the gripping end (on the peel side). For reels, pay attention to the opening direction/peeling direction.

A protective must be fitted to any pointed or sharp instruments before they are placed in pouches or reels.

MDs with a cavity (e.g. kidney dish) must be arranged such that their opening will face the paper side.

#### 3. Sealing pouches and reels

Pull tightly on the open end of pouches or reels so that the foil and paper lie evenly and free of folds in the guide mechanism on the feed-in side of the heat sealer until the device has transported the pouches or reels and a seam has been sealed.

If necessary, manually support transport while the seal seam is being produced.

Special care has to be taken when sealing gusseted pouches and reels: formation of any additional compression or shrinkage folds, giving rise to channels in the seal seam, must be avoided.

Recommendation: if gusseted pouches or reels can be replaced with larger sizes without a gusset this should be done in the interest of risk minimization.

#### 4. Visual inspection of the seal seam

Each seal must extend along the total width and length of the seal lines. There must not be any channels, kinks, folds, air pockets or notches. There must not be any signs of burning or melting.<sup>37</sup>

<sup>37</sup> The test method ASTM F1886 listed in ISO11607-1 Annex B «Standard test method for determining integrity of seals for medical packaging by visual inspection» can be used for routine visual inspection.

Compiled:	Reviewed:	Approved:
Date:	Date:	Date:



Logo of Institution	Quality Management Manual	Page of page
Department	Scope	Revision

**5. Protective packaging in the form of an outer see through wrap**

If a second wrap is specified in the packing instructions for the respective instrument, repeat steps 1 to 5, while paying attention additionally to the following:

- The pouch or reel size must permit unimpeded introduction of the inner wrap.
- The inner see through foil must not be kinked or folded. Attention must be paid to ensuring that the inner wrap is not sealed into the seal seam of the outer wrap.
- Make absolutely sure that the paper side of inner pouches and reels face the paper side of the outer pouches and reels.

**6. Labelling**

Labels should as a rule be affixed to the foil side.

If the label is to be affixed to the paper side, the size of the label must not exceed 20 % of the paper surface.

Do not affix labels to the seal seam.

Label only outside the seal seam and outside the area surrounding the sterile MD. To that effect, use ink cassettes that meet the requirements of DIN 58953-7.

In exceptional cases a suitable pen may be used to label outside the seal seam and the area enclosing the sterile MD. Here use only pens that meet the requirements of DIN 58953-7 (see Annex D for Sample Data Sheet for Sterilization Markers).

**7. Using a further protective packaging after sterilization**

This can be done, e. g. for transport and storage, protection as well as extension of the storage time, and is documented in the packing lists.

Compiled:	Reviewed:	Approved:
Date:	Date:	Date:

Logo of Institution	Quality Management Manual	Page of page
Department	Scope	Revision

### Annex A.7 : Sample standard operating procedure for verification of seal seams (daily when using)

**Scope**

This operating procedure is intended for all CSSD personnel who have successfully completed at least Specialist Training Course 1.

**Aim**

Daily routine visual inspection of the integrity and peelability of self-produced seal seams.

**I Standard reference:**

**Dye penetration test (ink test):**

ISO 11607-1 designates the dye penetration test as a test method for verification of the integrity of seal seams (e. g. ASTM F1929: Standard Test Method for Detecting Seal Leaks in Porous Medical Packaging by Dye Penetration).

**Peel test:**

EN 868-5, Annex E: «Method for determination of the peel characteristics of paper/plastic laminate products».

**Materials and prerequisites:**

- 1) Sealing device must be switched on and ready for operation (target temperature reached).
- 2) Dye penetration test pack (InkTest)<sup>38</sup>:
  - Suitable test ink with defined, very low viscosity
  - Pipette
  - Liquid-impermeable underlay
  - If necessary, small disposable cloth, handkerchief, or similar
- 3) Reel sections or pouches (approx. 20 cm width) of all see through packaging needed for the dye penetration test.
- 4) Reel sections of all see through packaging needed for the peel test<sup>39</sup>.

<sup>38</sup> Complete test packs are commercially available.

<sup>39</sup> If only pouch packaging is used, the peel test can be omitted after sterilization.

Compiled:	Reviewed:	Approved:
Date:	Date:	Date:

Logo of Institution	Quality Management Manual	Page of page
Department	Scope	Revision

### Procedure

1) Switch on the sealing device and wait until it has reached operating temperature.

#### *Dye penetration test (InkTest)<sup>40</sup>:*

- 2) Switch sealing device to test mode (if applicable)<sup>41</sup>.
- 3) Seal an empty pouch or reel section; width at least 20 cm/length approx. 10 cm.
- 4) Cut the pouch approximately 5 cm above the sealing seam (the reel section is already open at the top).
- 5) Using a pipette, inject around 2 ml of dye penetrant into the opened pouch or reel section just above the sealing seam. Using a finger or cloth, rub the testing ink along the sealing seam from the outside.
- 6) After around 20 seconds, check whether the sealing seam is intact.
- 7) Seal leaks in the sealing seam will be visible from the penetration of test ink.

Note: If left for a long time the extremely thin-liquid test ink can penetrate the porous material (paper or Tyvek<sup>®42</sup>) of the pouch or reel. This is not a leak.

#### *Peel test:*

- 8) Introduce reel section into sealing device and seal on peel side.
- 9) Expose sealed reel section to a sterilization cycle.
- 10) Slowly and carefully peel the seal joints apart by hand. Visually check that the seal extends along the total width and length of the seal lines. There must be no splitting of the paper more than 10 mm from the seal<sup>43</sup>. The results must be documented.

<sup>40</sup> Seal integrity indicators (e. g. Seal Check) can also be used for routine checks of seal seams.

<sup>41</sup> In the test mode (Seal Check mode) the critical sealing parameters as well as the name of test person, test date/time and serial number can be printed on the test packaging.

<sup>42</sup> Tyvek<sup>®</sup> is a registered trademark of E.I. du Pont de Nemours.

<sup>43</sup> Requirement as per EN 868-5, Annex E

Compiled:	Reviewed:	Approved:
Date:	Date:	Date:

**Annex B.1 : Validation plan checklist «sterilization sheets' folding and wrapping»**

- Initial validation
- Revalidation (at regular intervals, only performance requalification)
- Revalidation for special reasons (e. g. new materials)

**I a) Competences**

Name of institution (operator)	
Location	
Validator (name of persons, or companies, conducting validation)	
Responsible for overall validation (name/position)	

**I b) Description of reusable container**

Manufacturer			
Designation			
Supplier			
Contact person			
Manufacturer's CE conformity declaration available?* <sup>44</sup>	<input type="checkbox"/> Yes	<input type="checkbox"/> No	<input type="checkbox"/> Evidence
ISO 11607 Part 1 conformity?* <sup>45</sup>	<input type="checkbox"/> Yes	<input type="checkbox"/> No	<input type="checkbox"/> Evidence
Manufacturer's QM certificate available?*	<input type="checkbox"/> Yes	<input type="checkbox"/> No	<input type="checkbox"/> Evidence
Description of packaging material (porous material)**	<input type="checkbox"/> Crepe paper	<input type="checkbox"/> Nonwovens	<input type="checkbox"/> SMS non-wovens
	<input type="checkbox"/> Textile materials	<input type="checkbox"/> Other: _____	
Manufacturer's specifications and/or data sheet available <sup>46</sup>	<input type="checkbox"/> Yes	<input type="checkbox"/> No	<input type="checkbox"/> Evidence
with information on:			
Surface weight* (rated weight) g/m <sup>2</sup>	<input type="checkbox"/>		
Compatibility with respective sterilization process*	<input type="checkbox"/> STEAM	<input type="checkbox"/> EO (ethylene oxide)	<input type="checkbox"/> FORM (formaldehyde)
	<input type="checkbox"/> VH2O2 (plasma)	<input type="checkbox"/> Other:	
Label on protective and inner packaging (EN 868-2:2009)*	<input type="checkbox"/> Yes	<input type="checkbox"/> No	<input type="checkbox"/> Evidence

<sup>44</sup> The CE mark must be affixed to the outer packaging. The CE mark must not be affixed to the sheets supplied by the manufacturer (preformed sterile barrier system).

<sup>45</sup> Conformity with ISO 11607-1 is an absolute prerequisite and in general includes conformity with EN 868-2. Often, CE conformity and conformity with ISO 11607 Part 1 are declared jointly in one document.

<sup>46</sup> See Annex F: sample data sheet on crepe sheet materials.

with information on:	
– Reference, raw material or catalogue number*	<input type="checkbox"/>
– Quantity*	<input type="checkbox"/>
– Name of manufacturer or supplier or trademark and address*	<input type="checkbox"/>
– Batch number*	<input type="checkbox"/>
– Rated dimensions of sheets or rated width of rolls in millimetres as well as length in metres*	<input type="checkbox"/>
– Date of manufacture as per ISO 28601* <sup>47</sup>	<input type="checkbox"/>
– Recommended storage conditions*	<input type="checkbox"/>

\* Information featuring an \* must, in accordance with EN 868-2, be made available by the manufacturer of the packaging material.

\*\* For each material a complete checklist must be filled out and the validation process conducted.

### c) Description of closing system with or without indicator

Manufacturer/supplier			
Contact person			
Type/designation of closing system	<input type="checkbox"/> Adhesive tape without indicator (processed additionally) <input type="checkbox"/> Adhesive tape with indicator <input type="checkbox"/> Other: _____		
Manufacturer's/supplier's QM certificate available?	<input type="checkbox"/> Yes	<input type="checkbox"/> No	<input type="checkbox"/> Evidence
Have the recommended storage conditions been met?	<input type="checkbox"/> Yes	<input type="checkbox"/> No	<input type="checkbox"/> Evidence
Compatibility with packaging material			
– Crepe paper	<input type="checkbox"/> Yes	<input type="checkbox"/> No	Evidence <sup>48</sup> : _____
– Nonwovens	<input type="checkbox"/> Yes	<input type="checkbox"/> No	Evidence _____
– Textile material <sup>49</sup>	<input type="checkbox"/> Yes	<input type="checkbox"/> No	Evidence _____
Compatibility with respective sterilization process	<input type="checkbox"/> STEAM	<input type="checkbox"/> EO (ethylene oxide)	<input type="checkbox"/> FORM (formaldehyde)
	<input type="checkbox"/> VH2O2 (plasma)	<input type="checkbox"/> Other: _____	
Product characteristics of closing system – No toxicity	Information from manufacturer's data sheet		<input type="checkbox"/> Evidence
Type/designation of indicator	<input type="checkbox"/> Adhesive tape with indicator* <input type="checkbox"/> Other with indicator* _____		
* Conformity of indicator used with ISO 11140-1?	<input type="checkbox"/> Yes	<input type="checkbox"/> No	Evidence _____

<sup>47</sup> EN 868-2 does not call for specification of expiry date.

<sup>48</sup> Evidence can be provided on basis of data sheet or documented experience.

<sup>49</sup> Here a sterile barrier system is understood to mean only qualified materials as per EN 868-2.



**d) Description of another indicator used (EN ISO 11140-1)**

Manufacturer/supplier			
Contact person			
Designation			
Manufacturer's/supplier's QM certificate available?	<input type="checkbox"/> Yes	<input type="checkbox"/> No	Where? _____
DIN EN ISO 11140 Part 1 conformity? (e. g. non-toxic)	<input type="checkbox"/> Yes	<input type="checkbox"/> No	Evidence: _____
Have the storage conditions as recommended in the data sheet been met?	<input type="checkbox"/> Yes	<input type="checkbox"/> No	Evidence: _____
Compatibility with packaging material			
– Crepe paper	<input type="checkbox"/> Yes	<input type="checkbox"/> No	<input type="checkbox"/> Evidence
– Nonwovens	<input type="checkbox"/> Yes	<input type="checkbox"/> No	<input type="checkbox"/> Evidence
– Textile material <sup>50</sup>	<input type="checkbox"/> Yes	<input type="checkbox"/> No	<input type="checkbox"/> Evidence
Compatibility with respective sterilization process	<input type="checkbox"/> STEAM	<input type="checkbox"/> EO (ethylene oxide)	<input type="checkbox"/> FORM (formaldehyde)
	<input type="checkbox"/> VH2O2 (plasma)	<input type="checkbox"/> Other:	

**e) Description of sterilizations process**

Sterilization process	<input type="checkbox"/> STEAM		
Sterilization process validated?	<input type="checkbox"/> Yes	<input type="checkbox"/> No	
Validated by:			
Last validation:			
Validation report number(s): (if there is more than one sterilizer)			
Next validation:			

Sterilization process	<input type="checkbox"/> EO (ethylene oxide)		
Sterilization process validated?	<input type="checkbox"/> Yes	<input type="checkbox"/> No	
Validated by:			
Last validation:			
Validation report number(s): (if there is more than one sterilizer)			
Next validation:			

<sup>50</sup> Here a sterile barrier system is understood to mean only qualified materials as per EN 868-2.

Sterilization process	<input type="checkbox"/> VH2O2 (plasma)		
Sterilization process validated?	<input type="checkbox"/> Yes	<input type="checkbox"/> No	
Validated by:			
Last validation:			
Validation report number(s): (if there is more than one sterilizer)			
Next validation:			

Sterilization process	<input type="checkbox"/> FORM (formaldehyde)		
Sterilization process validated?	<input type="checkbox"/> Yes	<input type="checkbox"/> No	
Validated by:			
Last validation:			
Validation report number(s): (if there is more than one sterilizer)			
Next validation:			

Sterilization process	<input type="checkbox"/> Other: _____		
Sterilization process validated?	<input type="checkbox"/> Yes	<input type="checkbox"/> No	
Validated by:			
Last validation:			
Validation report number(s): (if there is more than one sterilizer)			
Next validation:			

**f) Qualification steps**

If this is an initial validation, all three qualification steps (IQ, OQ and PQ) must be carried out as per the checklists in Annex B.2, B.3 and B.4. For revalidation/performance requalification it may be possible to omit some steps.

<b>Installation qualification (IQ)</b>	<input type="checkbox"/> executed	
	<input type="checkbox"/> already executed during validation on _____	
	<input type="checkbox"/> passed	<input type="checkbox"/> failed
	Date/signature : _____	
<b>Operational qualification (OQ)</b>	<input type="checkbox"/> executed	
	<input type="checkbox"/> already executed during validation on _____	
	<input type="checkbox"/> passed	<input type="checkbox"/> failed
	Date/signature : _____	
<b>Performance qualification (PQ)</b>	<input type="checkbox"/> executed	
	<input type="checkbox"/> passed	<input type="checkbox"/> failed
	Date/signature : _____	

**g) Official approval of validation/revalidation by the operator**

- All parts of validation/revalidation passed.
- Parts of validation/revalidation failed.
- Measures have been defined and documented.

Place, date \_\_\_\_\_

Name \_\_\_\_\_

Signature \_\_\_\_\_

**Annex B.2 : Installation qualification (IQ) checklist «sterilization sheets’ folding and wrapping»**

Are standard operating procedures available (SOPs)? (e. g. as in Annex B.6)	<input type="checkbox"/> Yes	<input type="checkbox"/> No	<input type="checkbox"/> Where? _____
--	------------------------------	-----------------------------	--

**I a) Training**

Name of trained staff member	Training			Signature	
	By	Qualification	Date	Trainer	Trainee

Only if all users are inducted/trained will installation qualification be deemed to have been passed.

### Annexe B.3 : Operational qualification (OQ) checklist «sterilization sheets' folding and wrapping»

If the packaging system is composed of a sterile barrier system and protective packaging, the quality properties of both the sterile barrier system and protective packaging have to be verified for OQ.

Requirement for sample size (S) <sup>51</sup>		S ≥ 10	
Sample size (S)		S =	
Compliance with requirement	<input type="checkbox"/> Yes	<input type="checkbox"/> No	
Quality properties		Compliance	
Intact closeness/integrity		<input type="checkbox"/> Yes	<input type="checkbox"/> No
Evidence based on		_____	
Test method: _____		Name/signature	
No punctures (perforation) or tears		Protective packaging	Sterile barrier system
		<input type="checkbox"/> Yes <input type="checkbox"/> No	<input type="checkbox"/> Yes <input type="checkbox"/> No
Evidence based on		_____	
Test method: _____		Nom/signature	
No other visible damage or material irregularities		Protective packaging	Sterile barrier system
		<input type="checkbox"/> Yes <input type="checkbox"/> No	<input type="checkbox"/> Yes <input type="checkbox"/> No
Evidence based on		_____	
Test method: _____		Name/signature	

To document the quality properties, it is recommended that at least one photo be taken in addition of each sample.

51 ISO 11607-2 (§ 4.2) «The sampling plans used for selection and testing of packaging systems shall be applicable to the process being evaluated. Sampling plans shall be based upon a statistically valid rationale». The value of 10 is based on the experience made in practice. It can be seen as a statistical valid rationale in real life.

## Annex B.4 : Performance qualification (PQ) checklist «sterilization sheets' folding and wrapping»

Criteria	Sterilization cycle (batch) A		Sterilization cycle (batch) B		Sterilization cycle (batch) C	
Date/time of sterilization						
Sterilization protocol available and correct process sequence confirmed	<input type="checkbox"/> Yes	<input type="checkbox"/> No	<input type="checkbox"/> Yes	<input type="checkbox"/> No	<input type="checkbox"/> Yes	<input type="checkbox"/> No

Cycle (batch) A quality properties	Compliance	
Intact closeness/integrity	<input type="checkbox"/> Yes	<input type="checkbox"/> No
Evidence based on Test method: _____	_____ Name/signature	
No punctures (perforation) or tears	Protective packaging	Sterile barrier system
	<input type="checkbox"/> Yes <input type="checkbox"/> No	<input type="checkbox"/> Yes <input type="checkbox"/> No
Evidence based on Test method: _____	_____ Name/signature	
No other visible damage, contamination, material irregularities or residual moisture	Protective packaging	Sterile barrier system
	<input type="checkbox"/> Yes <input type="checkbox"/> No	<input type="checkbox"/> Yes <input type="checkbox"/> No
Evidence based on visual inspection Test method: _____	_____ Name/signature	
Compliance with defined packing method (DIN 58953-7 Annex A)	Protective packaging	Sterile barrier system
	<input type="checkbox"/> Yes <input type="checkbox"/> No	<input type="checkbox"/> Yes <input type="checkbox"/> No
Evidence based on photographic documentation	_____ Name/signature	

Cycle (batch) B quality properties	Compliance	
Intact closeness/integrity Evidence based on Test method: _____	<input type="checkbox"/> Yes	<input type="checkbox"/> No
_____ Name/signature		
No punctures (perforation) or tears Evidence based on Test method: _____	Protective packaging <input type="checkbox"/> Yes <input type="checkbox"/> No	Sterile barrier system <input type="checkbox"/> Yes <input type="checkbox"/> No
_____ Name/signature		
No other visible damage, contamination, material irregularities or residual moisture Evidence based on Test method: _____	Protective packaging <input type="checkbox"/> Yes <input type="checkbox"/> No	Sterile barrier system <input type="checkbox"/> Yes <input type="checkbox"/> No
_____ Name/signature		
Compliance with defined packing method (DIN 58953-7 Annex A) Evidence based on photographic documentation	Protective packaging <input type="checkbox"/> Yes <input type="checkbox"/> No	Sterile barrier system <input type="checkbox"/> Yes <input type="checkbox"/> No
_____ Name/signature		

Cycle (batch) C quality properties	Compliance	
Intact closeness/integrity Evidence based on Test method: _____	<input type="checkbox"/> Yes	<input type="checkbox"/> No
_____ Name/signature		
No punctures (perforation) or tears Evidence based on Test method: _____	Protective packaging <input type="checkbox"/> Yes <input type="checkbox"/> No	Sterile barrier system <input type="checkbox"/> Yes <input type="checkbox"/> No
_____ Name/signature		
No other visible damage, contamination, material irregularities or residual moisture Evidence based on Test method: _____	Protective packaging <input type="checkbox"/> Yes <input type="checkbox"/> No	Sterile barrier system <input type="checkbox"/> Yes <input type="checkbox"/> No
_____ Name/signature		
Compliance with defined packing method (DIN 58953-7 Annex A) Evidence based on photographic documentation	Protective packaging <input type="checkbox"/> Yes <input type="checkbox"/> No	Sterile barrier system <input type="checkbox"/> Yes <input type="checkbox"/> No
_____ Name/signature		

### Annex B.5 : Example for determining the scope of process validation per packaging material in combination with the sterilization process

#### *Example from everyday practice*

A Central Sterile Supply Department (CSSD) has three different steam sterilization programs as well as one formaldehyde sterilizer and one «plasma sterilizer», each with one program.

Materials are assigned as follows:

Packaging	STEAM			FORM (formal- dehyde)	EO (ethylene oxide)	VH2O2 (plasma)
	134 °C/5 min	134 °C/18 min	121 °C/20 min			
Material A (crepe paper)	×	x*	×			
Material B (nonwovens)	×	x*	×	x*		
Material C (SMS nonwovens)	×	x*	×	x*		x*
Material D (textile materials)	x*					

The 13 combinations outlined in the table can be reduced by taking account of only the maximum material stress (worst-case scenario, while providing documentary proof to justify this; in this example for material A, B and C: 134 °C/18 min). These combinations are marked with an x\* in the table. This shows that in this example validation needs to be carried out in total seven times. A further reduction can be achieved by a deliberate sterile barrier system (e. g. by using only two different materials). Accordingly, for this example the number of validations would be reduced from seven to five or even four.

Note: When using packaging sheets for FORM or EO sterilization one must ensure that the maximum residual content of sterilant permitted is not exceeded.

Packaging sheets containing paper (cellulose) absorb a certain amount of moisture with dissolved sterilization gases. When sheet packaging is used for packing purposes, a larger packaging surface is used and this increases the absolute residual content of sterilization gases compared with see through packaging. The most important thing is to measure the residual content of the entire packaging at the time of sterilization process validation.



Logo	Quality Assurance Manual	Page X / X
Department	Scope	Revision

### Annex B.6 : Sample standard operating procedure «sterilization sheets’ folding and wrapping»

Note: German Standard DIN 58953-7, § 6.2 and Annex A give a guide to packing with sterilization sheets. That guide has been used as a basis for compiling this sample standard operating procedure.

#### I a) Version A, diagonal packaging

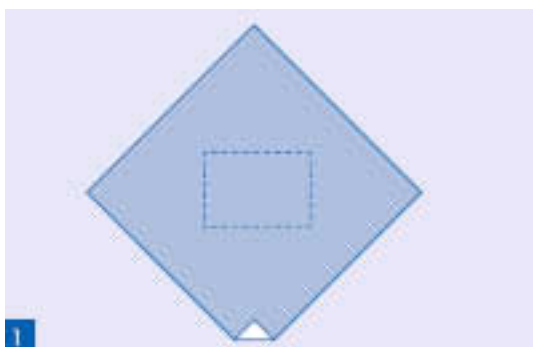

The item to be sterilized is placed in the centre of the sheet of paper such that its edges are at a right angel with the diagonals of the sheet of paper.

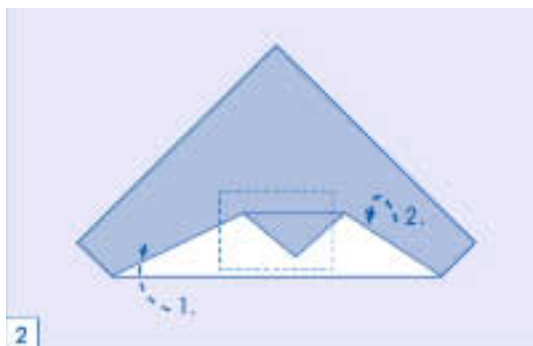

The sheet of paper is pulled upwards across the breadth of the item to be sterilized and folded back parallel to the longitudinal edge such that the item to be sterilized is fully covered. A triangle is now formed (point), providing for opening under aseptic (handling that ensures sterility) conditions.

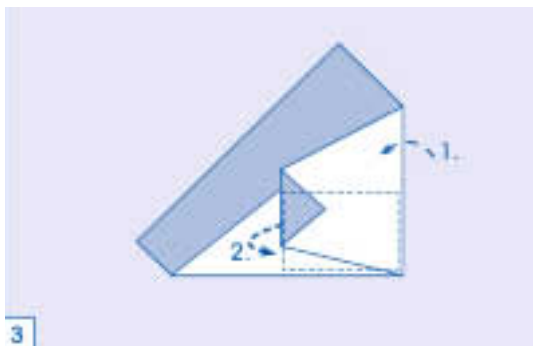

Proceed as in Fig. 2, but now working from the right and from the left.

Compiled:	Approved:	Released:
Date:	Date:	Date:

Logo	Quality Assurance Manual	Page X / X
Department	Scope	Revision

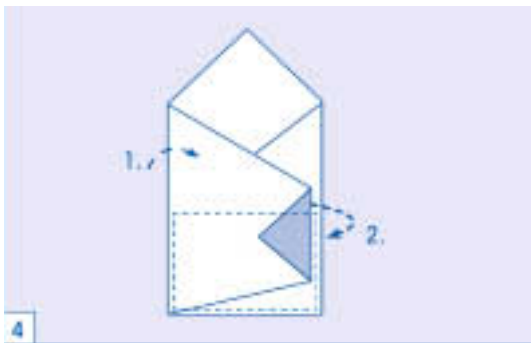

Repeat same procedure on opposite side, as in Fig. 3.

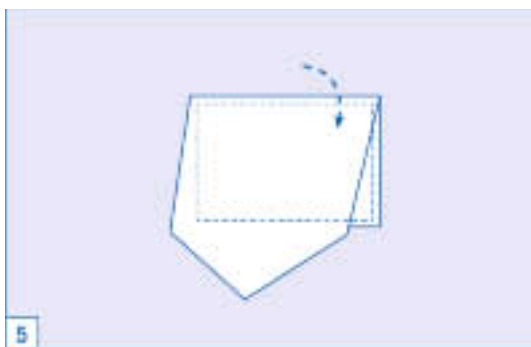

An open pocket is now formed at the top of the package on a longitudinal side.

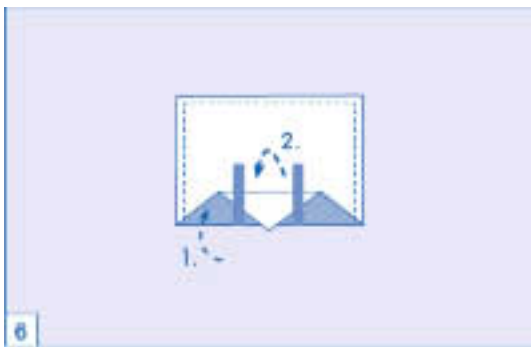

The last part of the sheet of paper is now pulled over the object to be packed and the point of the paper is inserted into the pocket until it just about sticks out.

The paper is then closed with a suitable closing system (e. g. adhesive tape and/or Class A indicator tape).

Compiled:	Approved:	Released:
Date:	Date:	Date:

Logo	Quality Assurance Manual	Page X / X
Department	Scope	Revision

**I b) Version B, parallel packaging**

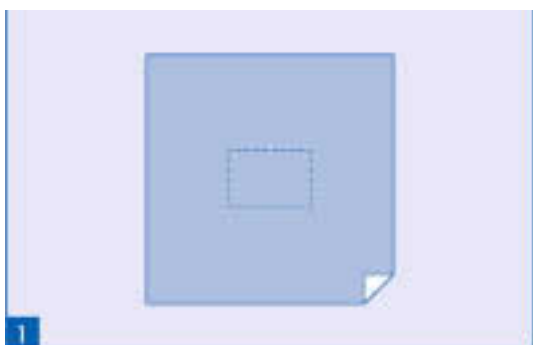

Place sterilization supplies (e. g. instrument tray) on centre of paper.

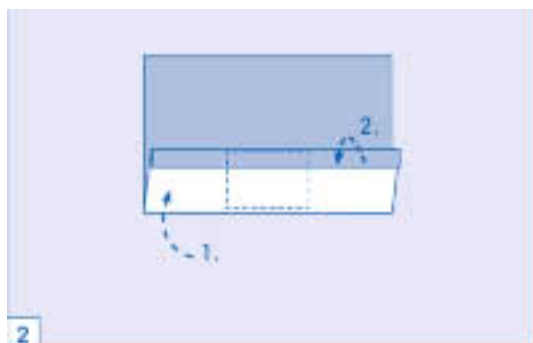

Place front of paper over the instrument tray

Fold edge of paper outwards, around as high as the sterilization supplies.

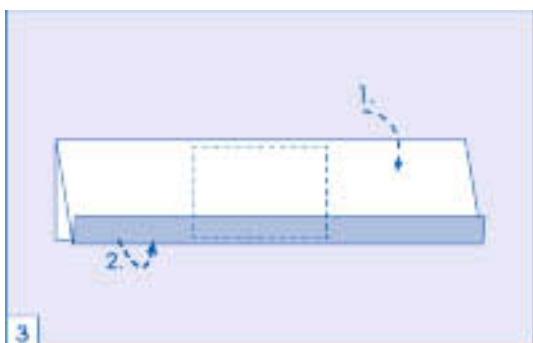

Fold back of paper forwards.

Fold edge of paper outwards; the paper closes with the front upper edge.

Compiled:	Approved:	Released:
Date:	Date:	Date:

Logo	Quality Assurance Manual	Page X / X
Department	Scope	Revision

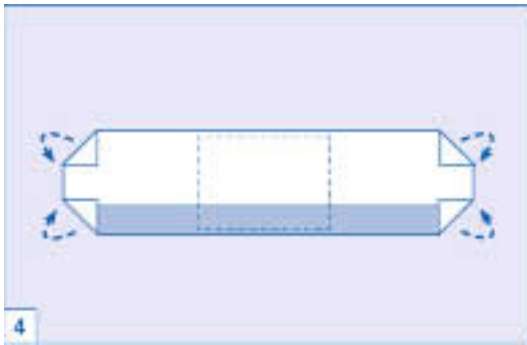

Fold paper at the side and place over the sterilization supplies, see Figs. 4 and 5.

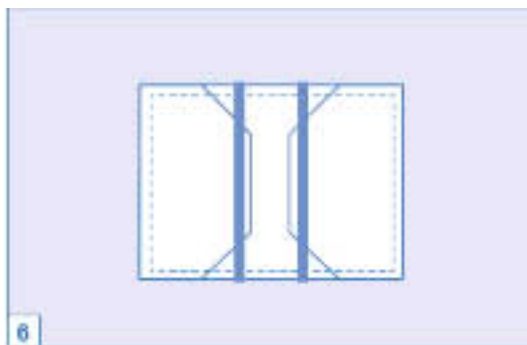
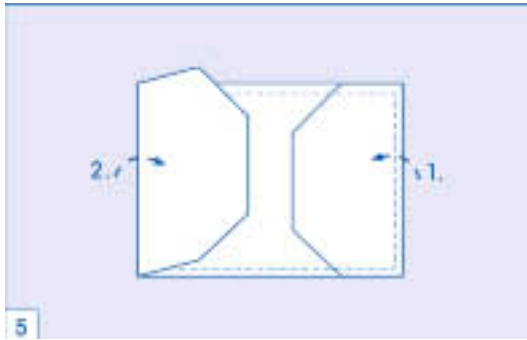

The paper is then closed with a suitable closing system (e. g. adhesive tape and/or Class A indicator tape).

Compiled:	Approved:	Released:
Date:	Date:	Date:

### Annex B.7 : Sample specification and sample data sheet, e. g. for «sterilization sheets»

Specifications and/or data sheets are descriptions of product characteristics compiled by the manufacturer or suppliers and they contain additional or more detailed information, in general on the minimum characteristics set out in the standard.

Whereas CE conformity is legally declared by the manufacturer or supplier through the use of the CE mark, legally binding compliance with product characteristics must be expressed separately in specifications and/or data sheets. This can be done e.g. by drawing attention to the specification on the invoice or delivery note.

<b>PRODUCT SPECIFICATION</b> <b>CREPE PAPER STERILIZATION SHEET «SAMPLE BRAND»</b> <b>ARTICLE GROUP 0310_01, 0310_02</b> <b>MANUFACTURER/SUPPLIER «SAMPLE ENTERPRISE»</b> <b>REVISION: 1</b> <b>DATE: 03/01/2011</b>
---

The technical values are guide values subjected to typical process fluctuations. They do not constitute grounds for dispensing with validation and operational qualification in any individual case.

Any measurement tolerances and packaging/labelling specifications (on agreement) deviating from the above shall be confirmed in the article text or in the print area indication/print drawing.

Product description	Packaging material for medical devices	
	Intended purpose	Depending on client's needs
	Sterilization suitability	Steam, EO/FO gas and GAMMA sterilization
	Standards	The packaging material complies with ISO 11607 Part 1 and EN 868 Part 2 Sections 4.2.1 and 4.2.2.2.
	Wear resistance	When stored as directed, products can be used for five years from date of manufacture (see recommended storage conditions)

Sizes	400 × 400 mm to 1200 × 1200 mm (tolerance ± 5 mm)
-------	---

Labelling cardboard boxes	Affix a label to the upperside of cardboard box. The label must contain the following information: – Supplier batch code – Material designation – Article No. – Size – Package contents (number of items) – Date (date of manufacture) – Expiry date
---------------------------	---

Packaging	Sheet materials are sealed in foil and packed in cardboard boxes
-----------	--

Technical data	Quality features	Value	Unit
	Surface weight:	60 ± 5 %	g/m <sup>2</sup>
	Colours:	0310_01 white 0310_02 green	

Recommended storage conditions	Temperature: + 15 °C to + 25 °C, Relative ambient humidity: 35 % – 50 % RH, store in dry place Protect against light or direct sun radiation. Open outer packaging only when product is to be used. Do not store close to: – Chemicals – Detergents
--------------------------------	---

**TECHNICAL DATA SHEET**  
**CREPE PAPER STERILIZATION SHEET «SAMPLE BRAND»**  
**MANUFACTURER/SUPPLIER «SAMPLE ENTERPRISE»**

This sterile barrier system complies with the following standards and directives:

ISO 11607-1:2009	EN 868-2:2009	European Medical Devices Directive 93/42/EEC
------------------	---------------	--

**Technical Data Sheets in compliance with EN 868-2:**

Chapter	Aspect	Test method	Unit	Requirement	Typical values
4.2.1	General				
	Raw materials	–	–	Primary raw material	Compliance
4.2.1.1	Colour fastness	ISO 6588-2	–	No leaching of colour from hot-water extract	Compliance
4.2.1.2	Mass/surface weight	ISO 536	g/m <sup>2</sup>	Mass must be within ± 5 % of rated value	60 g/m <sup>2</sup> ± 2 g
4.2.1.3	pH value	ISO 6588-2		5 ≤ pH ≤ 8	6.7
4.2.1.4	Chloride content	ISO 9197	%	Mass portion of chlorides NaCl ≤ 0.05 %	0.03 %
4.2.1.5	Sulphate content	ISO 9198	%	Mass portion of sodium sulphate Na <sub>2</sub> SO <sub>4</sub> ≤ 0.25 %	0.055 %
4.2.1.6	Fluorescence	NF Q03-059	%	Brightness ≤ 1 %, ≤ 5 spots of ≥ 1 mm <sup>2</sup> per 0.01 m <sup>2</sup>	Compliance
4.2.2.2	Crepe paper				
4.2.2.2.1	Creping	–	–	Creping for increased flexibility	Compliance
4.2.2.2.2	Fracture elongation	ISO 1924-2	%	≥ 10 % in machined direction (MD) ≥ 2 % in traverse direction (TD)	13 % 5 %
4.2.2.2.3	Water resistance	EN 868-2 Annex A	s	Penetration time ≥ 20 s	25
4.2.2.2.4	Pore diameter	Annex B	µm	Maximum pore diameter ≤ 50 µm	20 µm in Ø
4.2.2.2.5	Stretching	Annex C	mm	Max. stretching in MD ≤ 125 m In TD ≤ 160 mm	85 mm 148 mm
4.2.2.2.6	Tensile strength	ISO 1942-2	kN/m	MD ≥ 1.33 kN/m TD ≥ 0.67 kN/m	2.4 1.3
4.2.2.2.7	Wet strength	ISO 3781	kN/m	MD ≥ 0.33 kN/m TD ≥ 0.27 kN/m	0.8 0.45
Microbial impermeability as per ISO 11607:2009 Part 1:					
5.2.3	Microbial impermeability in dry state	DIN 58953-6: 2010, 2.14	–	No colonies on agar plates	No
	Microbial impermeability when moist	DIN 58953-6: 2010, 2.15	–	Max 20 % cycles	No
Sample enterprise Place, date* Name, Position*					

\* Specifications and/or data sheets can, but need not, be different.



# Products and systems from a single source... ...the specialist in sterile goods logistics!



Handling sterile goods efficiently and successfully in hospitals, clinics and sterilisation operations is not only a challenge, it is also a complex management function. HUPFER® - the specialist in sterile goods logistics - has the products and expertise not only to rise to the challenges of daily operational processes, but also to optimise established procedures. The individual logistics functions of these operational processes such as sorting, packing, arranging, transportation, storage and distribution are the basis and starting point for a smooth sterile goods cycle. HUPFER® develops and manufactures products and systems tailored to each individual logistics function. This product range enables the sterile goods cycle to be configured so as to create a complete process chain. The comprehensive range of items in each HUPFER® product line ensures specific support in making daily tasks easier, more efficient and more economical.

**HUPFER®**     
SPECIALIST IN STERILE GOODS LOGISTICS

## I Annex C.1: Validation plan checklist for packaging process with «filling and closing of reusable sterilization containers»

- Initial validation
- Revalidation (at regular intervals, only performance qualification)
- Revalidation for special reasons (e. g. new materials)

### I a) Competences

Name of institution (operator)	
Location	
Validator (name of persons, or companies, conducting validation)	
Responsible for overall validation (name/position)	

### I b) Description of reusable sterilization container

Manufacturer			
Designation			
Is the manufacturer's name visible on the product? (ISO 11607-1)			
Supplier			
Has the supplier been authorized by the manufacturer?	<input type="checkbox"/> Yes	<input type="checkbox"/> No	<input type="checkbox"/> Evidence
Supplier's contact person	Name:	Telephone number:	
Manufacturer's CE conformity declaration available? <sup>52</sup>	<input type="checkbox"/> Yes	<input type="checkbox"/> No	<input type="checkbox"/> Evidence
ISO 11607 Part 1 conformity? <sup>*</sup>	<input type="checkbox"/> Yes	<input type="checkbox"/> No	<input type="checkbox"/> Evidence
EN 868-8** conformity?	<input type="checkbox"/> Yes	<input type="checkbox"/> No	<input type="checkbox"/> Evidence
Manufacturer's QM certificate available? <sup>***</sup>	<input type="checkbox"/> Yes	<input type="checkbox"/> No	<input type="checkbox"/> Evidence
Is the operating manual available?	<input type="checkbox"/> Yes	<input type="checkbox"/> No	<input type="checkbox"/> Evidence
Is information available on cleaning and disinfection processes as per ISO 17664? <sup>53</sup>	Manual <input type="checkbox"/> Yes <input type="checkbox"/> No	Automated <input type="checkbox"/> Yes <input type="checkbox"/> No	

<sup>52</sup> Based on the Medical Devices Directive a sterilization container is a Class 1 medical device (medical device accessory).

<sup>53</sup> Preference must be given to automated cleaning and disinfection processes.



Compatibility with existing sterilization process (according to operating manual)	<input type="checkbox"/> STEAM EN 285	<input type="checkbox"/> EO (ethylene oxide)	<input type="checkbox"/> FORM (formaldehyde)
	<input type="checkbox"/> STEAM EN 13060	<input type="checkbox"/> Other:	
Sterile supplies' inner wrap as per DIN 58953-9?	<input type="checkbox"/> Yes	<input type="checkbox"/> No	
Are other consumables needed? If yes, from the same manufacturer as the sterilization container?	<input type="checkbox"/> Yes	<input type="checkbox"/> No (c and d omitted)	
Filter	<input type="checkbox"/> Yes (c omitted)	<input type="checkbox"/> No	
Seals	<input type="checkbox"/> Yes (d omitted)	<input type="checkbox"/> No	
Other (compile another table based on c and d)	<input type="checkbox"/> Yes	<input type="checkbox"/> No	

\* Information marked with \* must, in accordance with ISO 11607-1, be supplied by the manufacturer of the packaging material.

\*\* Information marked with \*\* is normally available when there is compliance with the provisions of the CE conformity declaration and with the provisions of ISO 11607-1.

\*\*\* Information marked with \*\*\* is normally available when there is compliance with the provisions of the CE conformity declaration.

**I c) Description of microbial barrier**

Type of microbial barrier	<input type="checkbox"/> Single-use filters <input type="checkbox"/> Reusable filters Number of decontamination cycles <sup>54</sup> : ..... <input type="checkbox"/> Closed valve <input type="checkbox"/> Pasteur loop		
Manufacturer			
Designation			
Is the manufacturer's name visible on the product/outer packaging?			
Supplier			
Contact person			
Manufacturer's CE mark and conformity declaration available? <sup>55</sup>	<input type="checkbox"/> Yes	<input type="checkbox"/> No	<input type="checkbox"/> Evidence
ISO 11607 Part 1 conformity? <sup>*</sup>	<input type="checkbox"/> Yes	<input type="checkbox"/> No	<input type="checkbox"/> Evidence
EN 868-2 <sup>**</sup> conformity?	<input type="checkbox"/> Yes	<input type="checkbox"/> No	<input type="checkbox"/> Evidence
Manufacturer's QM certificate available? <sup>***</sup>	<input type="checkbox"/> Yes	<input type="checkbox"/> No	<input type="checkbox"/> Evidence
Compatibility with respective sterilization process	<input type="checkbox"/> STEAM	<input type="checkbox"/> EO (ethylene oxide)	<input type="checkbox"/> FORM (formaldehyde)
	<input type="checkbox"/> VH2O2 (plasma)	<input type="checkbox"/> Other:	
Compatibility with reusable sterilization container named in b)	<input type="checkbox"/> Yes	<input type="checkbox"/> No	<input type="checkbox"/> Evidence
Reprocessable?	<input type="checkbox"/> Yes	<input type="checkbox"/> No	

**I d) Description of seals<sup>56</sup>**

Manufacturer			
Designation			
Is the manufacturer's name visible on the product/outer packaging? (ISO 11607-1:2009, ...)?			
Supplier			
Contact person			
Manufacturer's QM certificate available?	<input type="checkbox"/> Yes	<input type="checkbox"/> No	<input type="checkbox"/> Evidence
Compatibility with respective sterilization process	<input type="checkbox"/> STEAM	<input type="checkbox"/> EO (ethylene oxide)	<input type="checkbox"/> FORM (formaldehyde)
	<input type="checkbox"/> VH2O2 (plasma)	<input type="checkbox"/> Other:	
Compatibility with reusable sterilization container named in b)	<input type="checkbox"/> Yes	<input type="checkbox"/> No	<input type="checkbox"/> Evidence

\* Information marked with \* must, in accordance with ISO 11607-1, be supplied by the manufacturer of the packaging material.

\*\* Information marked with \*\* is normally available when there is compliance with the provisions of the CE conformity declaration and with the provisions of ISO 11607-1.

\*\*\* Information marked with \*\*\* is normally available when there is compliance with the provisions of the CE conformity declaration.

<sup>54</sup> The number of cycles must be documented.

<sup>55</sup> The CE mark must be affixed to the sterilization container.

<sup>56</sup> CE mark not required

**I e) Description of the sterilization process**

Describe only the sterilization processes with which the sterile barrier system described under b) is sterilized.

Sterilization process	<input type="checkbox"/> STEAM		
Sterilization process validated?	<input type="checkbox"/> Yes	<input type="checkbox"/> No	
Validated by:			
Last validation:			
Validation report number(s): (if there is more than one sterilizer)			
Next validation:			

Sterilization process	<input type="checkbox"/> EO (ethylene oxide)		
Sterilization process validated?	<input type="checkbox"/> Yes	<input type="checkbox"/> No	
Validated by:			
Last validation:			
Validation report number(s): (if there is more than one sterilizer)			
Next validation:			

Sterilization process	<input type="checkbox"/> VH2O2 (plasma)		
Sterilization process validated?	<input type="checkbox"/> Yes	<input type="checkbox"/> No	
Validated by:			
Last validation:			
Validation report number(s): (if there is more than one sterilizer)			
Next validation:			

Sterilization process	<input type="checkbox"/> Other: _____		
Sterilization process validated?	<input type="checkbox"/> Yes	<input type="checkbox"/> No	
Validated by:			
Last validation:			
Validation report number(s): (if there is more than one sterilizer)			
Next validation:			

### f) Qualification steps

If this is an initial validation, all three qualification steps (IQ, OQ and PQ) must be carried out as per the checklists in Annex C.2, C.3 and C.4. For revalidation / performance requalification it may be possible to omit some steps.

<b>Installation qualification (IQ)</b>	<input type="checkbox"/> executed	
	<input type="checkbox"/> already executed during validation on _____	
	<input type="checkbox"/> passed	<input type="checkbox"/> failed
	Date/signature : _____	
<b>Operational qualification (OQ)</b>	<input type="checkbox"/> executed	
	<input type="checkbox"/> already executed during validation on _____	
	<input type="checkbox"/> passed	<input type="checkbox"/> failed
	Date/signature : _____	
<b>Performance qualification (PQ)</b>	<input type="checkbox"/> executed	
	<input type="checkbox"/> passed	<input type="checkbox"/> failed
	Date/signature : _____	

### g) Official approval of validation/revalidation by the operator

- All parts of validation/revalidation passed
- Parts of validation/revalidation failed
- Measures have been defined and documented

*Place, date* \_\_\_\_\_

*Name* \_\_\_\_\_

*Signature* \_\_\_\_\_

# 100%

# Green

No <sup>paper</sup> filter.  
No waste.  
No costs.



The MicroStop® sterilization container. Sustainability that really pays off.

**Annex C.2: Installation qualification (IQ) checklist «filling and closing of reusable sterilization containers»**

Are standard operating procedures available (SOPs)? (example as in Annex C.6)	<input type="checkbox"/> Yes	<input type="checkbox"/> No	<input type="checkbox"/> Where? _____
--	------------------------------	-----------------------------	--

Document	Available		Where (archival site)
Operating manual	<input type="checkbox"/> Yes	<input type="checkbox"/> No	
CE conformity declaration <sup>57</sup>	<input type="checkbox"/> Yes	<input type="checkbox"/> No	
Consumables – order list	<input type="checkbox"/> Yes	<input type="checkbox"/> No	
Compliance	<input type="checkbox"/> Yes	<input type="checkbox"/> No	Date/signature : _____

Individual labelling of sterilization container (including lid)	Year of manufacture	Is the sterilization container defective? (if No, approve and sign)	Take remedial action if defective	Is the sterilization container defective after taking remedial action? (if No, approve and sign)	Approval/signature
		<input type="checkbox"/> Yes <input type="checkbox"/> No	<input type="checkbox"/> Yes Which:  Signature:	<input type="checkbox"/> Yes <input type="checkbox"/> No	
		<input type="checkbox"/> Yes <input type="checkbox"/> No	<input type="checkbox"/> Yes Which:  Signature:	<input type="checkbox"/> Yes <input type="checkbox"/> No	

<sup>57</sup> The CE conformity declaration is normally part of the operating manual.



### I Annex C.3: Operational qualification (OQ) checklist «filling and closing of reusable sterilization containers»

If the sterilization container has an inner wrap, the quality properties of both the sterilization container and inner wrap have to be verified for OQ.

Requirement for sample size (S) <sup>58</sup>		S ≥ 10	
Sample size (S)		S =	
<b>Compliance with requirement</b>		<input type="checkbox"/> Yes	<input type="checkbox"/> No
<b>Quality properties</b>		<b>Compliance</b>	
<b>Intact</b> closeness/integrity		<input type="checkbox"/> Yes	<input type="checkbox"/> No
Evidence based on		_____	
Test method: _____		Name/signature	
<b>No</b> visible damage or material irregularities		Sterilization container	Inner wrap
		<input type="checkbox"/> Yes <input type="checkbox"/> No	<input type="checkbox"/> Yes <input type="checkbox"/> No
Evidence based on		_____	
Test method: _____		Name/signature	

To document the quality properties, it is recommended that at least one photo be taken in addition of each sample.

<sup>58</sup> ISO 11607-2 (§ 4.2) «The sampling plans used for selection and testing of packaging systems shall be applicable to the process being evaluated. Sampling plans shall be based upon a statistically valid rationale». The value of 10 is based on the experience made in practice. It can be seen as a statistical valid rationale in real life.



**Annex C.4: Performance qualification (PQ) checklist «filling and closing of reusable sterilization containers»**

Criteria	Sterilization cycle (batch) A		Sterilization cycle (batch) B		Sterilization cycle (batch) C	
Date/time of sterilisation						
Sterilization protocol available and correct process sequence confirmed	<input type="checkbox"/> Yes	<input type="checkbox"/> No	<input type="checkbox"/> Yes	<input type="checkbox"/> No	<input type="checkbox"/> Yes	<input type="checkbox"/> No

Cycle (batch) A quality properties	Compliance	
<b>Intact</b> closeness/integrity	<input type="checkbox"/> Yes	<input type="checkbox"/> No
Evidence based on	_____	
Test method: _____	Name/signature	
<b>No</b> visible damage, contamination, material irregularities or residual moisture	Sterilization container	Inner wrap
	<input type="checkbox"/> Yes <input type="checkbox"/> No	<input type="checkbox"/> Yes <input type="checkbox"/> No
Evidence based on	_____	
Test method: _____	Name/signature	
Compliance with defined packing method	Sterilization container	Inner wrap
	<input type="checkbox"/> Yes <input type="checkbox"/> No	<input type="checkbox"/> Yes <input type="checkbox"/> No
Evidence based on photographic documentation	_____	
	Name/signature	

Cycle (batch) B quality properties	Compliance	
<b>Intact</b> closeness/integrity	<input type="checkbox"/> Yes	<input type="checkbox"/> No
Evidence based on	_____	
Test method: _____	Name/signature	
<b>No</b> visible damage, contamination, material irregularities or residual moisture	Sterilization container	Inner wrap
	<input type="checkbox"/> Yes <input type="checkbox"/> No	<input type="checkbox"/> Yes <input type="checkbox"/> No
Evidence based on	_____	
Test method: _____	Name/signature	
Compliance with defined packing method	Sterilization container	Inner wrap
	<input type="checkbox"/> Yes <input type="checkbox"/> No	<input type="checkbox"/> Yes <input type="checkbox"/> No
Evidence based on photographic documentation	_____	
	Name/signature	

Cycle (batch) C quality properties	Compliance	
<b>Intact</b> closeness/integrity  Evidence based on _____ Test method: _____	<input type="checkbox"/> Yes	<input type="checkbox"/> No
<b>No</b> visible damage, contamination, material irregularities or residual moisture  Evidence based on _____ Test method: _____	Sterilization container <input type="checkbox"/> Yes <input type="checkbox"/> No	Inner wrap <input type="checkbox"/> Yes <input type="checkbox"/> No
Compliance with defined packing method  Evidence based on photographic documentation	Sterilization container <input type="checkbox"/> Yes <input type="checkbox"/> No	Inner wrap <input type="checkbox"/> Yes <input type="checkbox"/> No
	_____ Name/signature	

### Annex C.5: Example for determining scope of process validation per sterilization container in combination with the sterilization processes

Packaging	STEAM			EO (ethylene oxide)	VH2O2 (plasma)
	134 °C/5 min	134 °C/18 min	121 °C/20 min		
1) Sterilization container from manufacturer A (with permanent filter, without inner wrap)	×	×*	×		
2) Sterilization container from manufacturer B/filters from manufacturer B with inner wrap	×	×*	×		
3) Sterilization container from manufacturer B/filters from manufacturer C with inner wrap	×	×*	×	×*	
4) Sterilization container from manufacturer B/filters from manufacturer C without inner wrap	×	×	×		×*

The 14 combinations outlined in the table can be reduced by taking account of only the maximum material stress (worst-case scenario, while providing documentary proof to justify this). These combinations are marked with an ×\* in the table. This example shows that in total validation must be carried out five times. A further reduction can be achieved by opting for standardization (e. g. using only one filter or sterilization container or sterilization container/filter system).

Logo	Quality Assurance Manual	Page X / X
Department	Scope	Revision

### Annex C.6: Sample standard operating procedure «filling and closing of reusable sterilization containers»

**Note:** German Standard DIN 58953-9, § 6 gives a guide to packing reusable sterilization containers. That guide has been used as a basis for compiling this sample standard operating procedure.

1. Aim:  
After this procedural step, the packaging system must be available and ready for the sterilization process step.
2. Scope of application:  
Clean side of CSSD.
3. Preparation:
  - 3.1 Trays must be first packed as a precondition for packing in sterilization containers.
  - 3.2 Compliance with the maximum loading heights specified in the manufacturer's instructions must be assured.
  - 3.3 For ergonomic reasons and to avoid excessive condensation, the weight of the load should not exceed 10 kg (as per EN 868, Part 8).
4. 4. Workflow pattern:
  - 4.1 Perform a functional test in accordance with the instructions of the manufacturer of the respective sterilization container.
  - 4.2 If necessary, fit a microbial barrier in the packaging system at the sites specified in the manufacturer's instructions.
  - 4.3 Insert the prepared trays with or without an inner wrap.
  - 4.4 The sterilization container lid must be fitted to the container tank without exerting any pressure and closed in accordance with the instructions of the manufacturer of the respective closing system.
  - 4.5 If necessary, fit a sealing system to the prescribed sites to protect against unauthorized opening, e.g. in the form of a seal.
  - 4.6 The sterilization container must feature at least the following information:
    - Name of packer,
    - Proprietors and content,
    - Documentation of sterilization date.
  - 4.7 Load trolley for the sterilizer as per the manufacturer's instructions.
  - 4.8 Last visual inspection before closing door.
  - 4.9 Before activating start button, verify whether prescribed program has been selected.
5. Accompanying documents:
  - Operating instructions
  - Sterilization container
  - Sterilizer
  - Preliminary and subsequent CSSD operating procedures
  - Validation documentation

Compiled:	Approved:	Released:
Date:	Date:	Date:

## Annex D: Sample data sheet «sterilization markers»

<b>Technical Data Sheet</b> <b>Sterilization Markers</b> <b>Manufacturer/supplier «sample enterprise»</b>
---

Description:	Sterilization markers
Features:	n-propanol/ethanol, does not contain xylool or toluol. Waterproof on most surfaces. Odourless.
Colours:	Organic colours. Ingredients based on latest technical information sources.
Sheath:	Polypropylene PP
Test standard:	ISO 554
Inspection:	Based on Batch No.
Test :	As per prescribed procedure
Shelf life:	2 years after date of manufacture



**Editor in Chief**

P. Heeg, Tübingen, Germany

**Editors**

P. Heeg, Tübingen (D), W. Renders, Brugge (B), W. Spencer, Selby (GB), D. Talon, Paris (F)

**Advisory Editorial Board**

W. Accoe, Gent (B), M. Alfa, Winnipeg (CDN), M. Borneff-Lipp, Halle (D), A. Carter, Rödighausen (D), F. Cavin, Lausanne (CH), E. Denhöfer, Köln (D), C. Faber, Brüssel (B), T. Fenger, Berlin (D), D. Gouillet, Lyon (F), P. Holland, Kingston-upon-Thames (GB), U. Junghannß, Köthen (D), W. Kohnen, Mainz (D), S. Krüger, Grünendeich (D), H. Martiny, Berlin (D), A.P. Mercieca, Sydney (AUS), T. Miorini, Graz (A), K. Roth, Tübingen (D), A. Schneider, Pforzheim (D), G.A. Sills, Nottingham (GB), Y. Uetera, Tokyo (Japan), P.A. de Vries, Utrecht (NL), T. Zannette, Tübingen (D)

Central Service is the official publication of the German Society for Sterile Supply e.V. (DGSV).

**Publisher**

mhp-Verlag GmbH, CEO Andreas Klein, Markt- platz 13, D-65183 Wiesbaden. Tel.: +49 (0) 611/505 93-31, Fax: -11, E-mail: info@mhp- verlag.de

**Editorial Staff**

Dr. Gudrun Westermann, Tel.: +49 (0) 611/505 93-34, Fax: -11, E-mail: ZentrSteril@mhp-ver- lag.de

**Advertising Sales**

Walter Bockemühl Tel.: +49 (0) 611/505 93-32

**Rate Card**

No. 20/2012

**Printing**

Druckerei Chmielorz GmbH, Ostring 13, D-65205 Wiesbaden-Nordenstadt

**Paper**

Terraprint mat «chlorine-free», 80 g/sq.m

**Publication Schedule**

Bimonthly: February, April, June, August, Oc- tober, December

**Subscription Rates**

Single issue: € 10.00 (+ postage). Annual subscription (incl. postage): Print: Germany: € 66.60; Europe: € 77.00; World (air mail, + tax): € 89.50. E-Paper: Germany: € 65.00; Eu- rope: € 65.00; World (w/o tax): € 54.62. Kombi Print/E-Paper: Germany: € 82.85; Europe: € 93,25; World (air mail included, + tax): € 103,16.

Unless cancelled 6 weeks before the end of the current year, the subscription is automatically continued for another year. Subscription orders should be sent to the publisher.

For more information see [www.mhp-verlag.de](http://www.mhp-verlag.de)

**Copyright**

All rights reserved. No part of this publication may be reproduced, transmitted in any form or by any means without the prior written per- mission of mhp-Verlag GmbH. One photoco- py of individual articles or parts thereof may be made for personal use only. © mhp-Verlag GmbH 2012

**Trademarks**

The use of general descriptive names, trade names, trademarks, etc., even if these are not especially identified, is not to be taken as sign that such names may be used freely by anyone. Editor in Chief, Editorial Board and publisher do not guarantee for articles published outside the editorial part of the journal (esp. adverti- sing, industrial information). Authors who are mentioned with their full name and who are not member of the editorial staff publish articles in their own responsibility.

ISSN 0942-6086



**YES, I would like to subscribe to *Central Service*.**

I will pay after receipt of your invoice.

I wish to pay by Credit Card:

Visa  Master Card  AmEx

No.

Safety no.

**FAX +49 (0) 611/505 93-11**

You can cancel your order by writing to the publisher within 14 days from the date of submission.

**Sender**

Name

Establishment

Address

Date, Signature



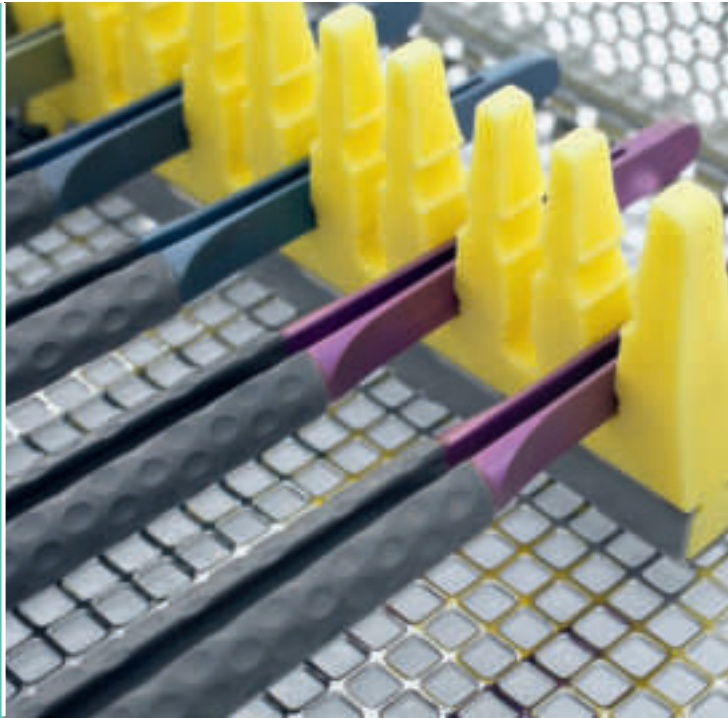

# » AIOS – The Smile System. «

## AESCULAP® Instrument Organisation System

### Organise and protect your surgical instruments

Our new AIOS organisation system for the supply of sterile products makes clever organisation and efficient processes easy. The multi-faceted system is specially designed for Aesculap instrument trays and is easy to assemble. The racks are fitted in seconds with pins or clamps. Done!

### Why not try the AIOS starter kit for an easy, practical introduction.

For more information, please visit:  
[www.sterilecontainer-aesculap.com](http://www.sterilecontainer-aesculap.com)



**B | BRAUN**  
 SHARING EXPERTISE

Aesculap AG | Am Aesculap-Platz | 78532 Tuttlingen | Germany  
 Phone +49 (0) 74 61 95-0 | Fax +49 (0) 74 61 95-26 00 | [www.aesculap.com](http://www.aesculap.com)

Aesculap – a B. Braun company